

Item # 1000 772 228

Model # TF291204



## USE AND CARE GUIDE

### 80-GALLON STATIONARY AIR COMPRESSOR

Questions, problems, missing parts?  
Before returning to the store, call  
Husky Customer Service  
8 a.m. - 6 p.m., EST, Monday - Friday

1-888-43-HUSKY

HUSKYTOOLS.COM

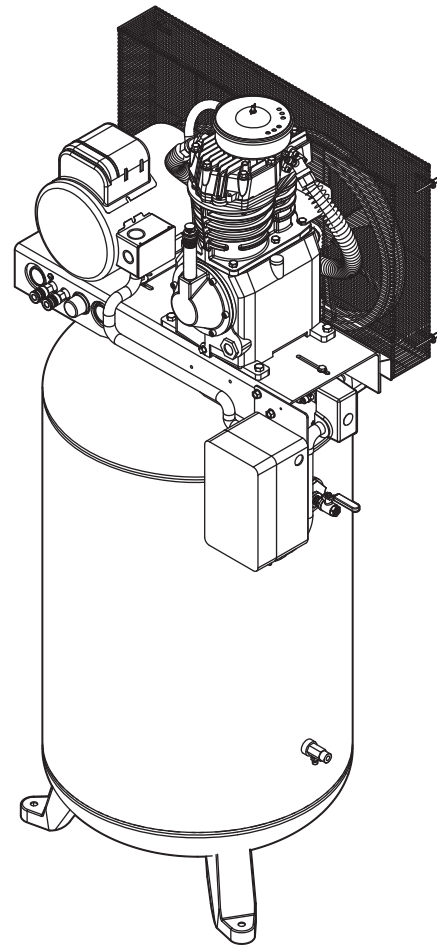

#### **THANK YOU**

*We appreciate the trust and confidence you have placed in Husky through the purchase of this air compressor. We strive to continually create quality products designed to enhance your home. Visit us online to see our full line of products available for your home improvement needs.*

*Thank you for choosing Husky!*

# Table of Contents

<b>Safety Information</b> . . . . .	<b>2</b>	<b>Installation - Mounting.</b> . . . . .	<b>11</b>
California Proposition 65 . . . . .	2	<b>Installation - Electrical.</b> . . . . .	<b>13</b>
General Safety . . . . .	3	<b>Assembly.</b> . . . . .	<b>16</b>
Work Area Safety . . . . .	4	<b>Operation.</b> . . . . .	<b>17</b>
Personal Safety . . . . .	5	<b>Maintenance .</b> . . . .	<b>19</b>
Electrical Safety . . . . .	5	<b>Care and Cleaning .</b> . . . .	<b>23</b>
Spraying Precautions. . . . .	5	<b>Troubleshooting .</b> . . . .	<b>24</b>
<b>Warranty</b> . . . . .	<b>6</b>	<b>Service Parts.</b> . . . . .	<b>28</b>
<b>Pre-Installation.</b> . . . . .	<b>7</b>		
Tools Required . . . . .	7		
Hardware Required . . . . .	7		
Package Contents . . . . .	8		
Compressor Components. . . . .	9		
Specifications . . . . .	10		

## Safety Information

This manual contains information that is very important to know and understand. This information is provided for SAFETY and to PREVENT EQUIPMENT PROBLEMS. To help recognize this information, observe the following symbols.

 **DANGER:** Indicates an imminently hazardous situation which, if not avoided, WILL result in death or serious injury.

 **WARNING:** Indicates a potentially hazardous situation which, if not avoided, COULD result in death or serious injury.

 **CAUTION:** Indicates a potentially hazardous situation which, if not avoided, MAY result in minor or moderate injury.

 **IMPORTANT:** Indicates important information, that if not followed, may cause damage to equipment.

 **NOTE:** Information that requires special attention.

### CALIFORNIA PROPOSITION 65

 **WARNING:** This product or its power cord may contain chemicals known to the State of California to cause cancer and birth defects or other reproductive harm. Wash hands after handling.

 **WARNING:** You can create dust when you cut, sand, drill, or grind materials such as wood, paint, metal, concrete, cement, or other masonry. This dust often contains chemicals known to cause cancer, birth defects, or other reproductive harm. Wear protective gear.

# Safety Information (continued)

## GENERAL SAFETY



**DANGER:** Breathable Air Warning: This compressor/pump is NOT equipped and should NOT be used “as is” to supply breathing quality air. For any application of air for human consumption, you must fit the air compressor/pump with suitable in-line safety and alarm equipment. This additional equipment is necessary to properly filter and purify the air to meet minimal specifications for Grade D breathing as described in Compressed Gas Association Commodity Specification G 7.1, OSHA 29 CFR 1910. 134, and/or Canadian Standards Associations (CSA).

Disclaimer of Warranties: In the event the compressor is used for the purpose of breathing air application and proper in-line safety and alarm equipment is not simultaneously used, existing warranties are void, and the Manufacturer disclaims any liability whatsoever for any loss, personal injury, or damage.



**DANGER:** Never attempt to repair or modify a tank! Welding, drilling, or any other modification will weaken the tank, resulting in damage from rupture or explosion. Always replace worn, cracked, or damaged tanks.



**CAUTION:** See the compressor specification decal for maximum operating pressure. Do not operate with pressure switch or pilot valves set higher than the maximum operating pressure.



**IMPORTANT:** Drain liquid from the tank daily.



**NOTE:** The **DANGER**, **WARNING**, **CAUTION**, **IMPORTANT**, and **NOTE** notifications and instructions in this manual cannot cover all possible conditions and situations that may occur. It must be understood by the operator that caution is a factor which cannot be built into this product, but must be supplied by the operator.

1. Read all manuals included with this product carefully. Be thoroughly familiar with the controls and the proper use of the equipment.
2. Only persons well acquainted with these rules of safe operation should be allowed to use the compressor.
3. Tanks rust from moisture build-up, which weakens the tank. Make sure to drain the tank regularly and inspect periodically for unsafe conditions, such as rust formation and corrosion.
4. Fast moving air will stir up dust and debris which may be harmful. Release air slowly when draining moisture or depressurizing the compressor system.

# Safety Information (continued)

## WORK AREA SAFETY



**WARNING:** Motors, electrical equipment, and controls can cause electrical arcs that will ignite a flammable gas or vapor. Never operate or repair in or near a flammable gas or vapor. Never store flammable liquids or gases in the vicinity of the compressor.



**WARNING:** An ASME code safety relief valve with a setting no higher than the maximum allowable working pressure (MAWP) MUST be installed in the tank for this compressor. The ASME safety valve must have sufficient flow and pressure ratings to protect the pressurized components from bursting.



**WARNING:** Never use plastic (PVC) pipe for compressed air. Serious injury or death could result.



**WARNING:** This compressor is extremely top heavy. The unit must be bolted to the floor with isolation pads before operating to prevent equipment damage, injury, or death.



**WARNING:** Do not modify this compressor. Do not use or create accessories not recommended for use with this compressor. Alterations and/or modifications are a form of misuse, which could result in a hazardous condition leading to possible personal injury or equipment damage.



**CAUTION:** Do not use this compressor in an environment where the air is contaminated or dusty. Using this compressor in such an environment may cause equipment damage.

1. Keep visitors away from the compressor, and NEVER allow children in the work area.
2. Before each use, inspect the compressed air system and electrical components for signs of damage, deterioration, weakness, or leakage. Repair or replace defective items before using.
3. Check all fasteners at frequent intervals for proper tightness.
4. If the equipment should start to vibrate abnormally, STOP the engine/motor and check immediately for the cause. Vibration is generally a warning of trouble.
5. To reduce fire hazard, keep the engine/motor exterior free of oil, solvent, or excessive grease.
6. Never attempt to adjust the ASME safety valve. Keep the safety valve free from paint and other accumulations.

# Safety Information (continued)

## PERSONAL SAFETY



**WARNING:** Never operate the compressor without a beltguard. This unit can start automatically without warning. Personal injury or property damage could occur from contact with moving parts.



**CAUTION:** Compressor parts may be hot even if the unit is stopped.

1. Wear safety glasses and use hearing protection when operating the unit.
2. Do not stand on or use the unit as a handhold.
3. Do not wear loose clothing or jewelry that will get caught in the moving parts of the unit.
4. Keep fingers away from a running compressor; fast moving and hot parts will cause injury and/or burns. Compressor parts may be hot even if the unit is stopped.

## ELECTRICAL SAFETY



**WARNING:** Improper electrical grounding can result in electrical shock. The wiring should be done by a qualified electrician.



**CAUTION:** Improper electrical installation of this product may void its warranty. Have circuit wiring performed by qualified personnel, such as a licensed electrician who is familiar with the current national and local electrical codes.

1. Follow all local electrical and safety codes as well as in the United States, the National Electrical Codes (NEC), and Occupational Safety and Health Act (OSHA).
2. Avoid body contact with grounded surfaces such as pipes, radiators, ranges, and refrigerators. There is an increased risk of electric shock if your body is grounded.
3. Do not expose power tools to rain or wet conditions. Water entering a power tool will increase the risk of electric shock.
4. Replace damaged cords/wiring immediately. Damaged cords/wiring increase the risk of electric shock.

## SPRAYING PRECAUTIONS



**WARNING:** Do not spray flammable materials in the vicinity of open flame or near ignition sources including the compressor unit.

1. Do not smoke when spraying paint, insecticides, or other flammable substances.
2. Use a face mask/respirator when spraying and spray in a well ventilated area to prevent health and fire hazards.
3. Do not direct paint or other sprayed material at the compressor. Locate the compressor as far away from the spraying area as possible to minimize overspray accumulation on the compressor.
4. When spraying or cleaning with solvents or toxic chemicals, follow the instructions provided by the chemical manufacturer.

# Warranty

## LIMITED TWO-YEAR WARRANTY

### WHAT IS COVERED

From the date of purchase, parts and labor are covered to remedy substantial defects due to material and workmanship during the first year of ownership with the exceptions noted below. From the date of purchase, parts only are covered to remedy substantial defects due to material and workmanship during the second year of coverage with exceptions noted below.

This warranty applies only to the original retail purchaser and may not be transferred. If the compressor is used for commercial, industrial, or rental purposes, the warranty will apply for ninety (90) days from the date of purchase. Two-stage compressors are not limited to a ninety (90) day warranty when used in commercial or industrial applications. Some states do not allow limitations on how long an implied warranty lasts, so the above limitations may not apply to you.

**WARRANTOR:** Campbell Hausfeld/Scott Fetzer Company, 100 Production Drive, Harrison, Ohio, 45030 Telephone: (800) 543-6400

The responsibilities of the warrantor under this warranty is to repair or replace, at the warrantor's option, this compressor or components which are defective, have malfunctioned, and/or have failed to conform within the duration of the specific warranty period. Repair or replacement will be scheduled and serviced according to the normal work-flow at the servicing location and will depend on the availability of replacement parts.

The responsibilities of the purchaser under this warranty are as follows: a) provide dated proof of purchase and maintenance records; b) call to obtain your warranty service options [freight costs must be borne by the purchaser]; c) use reasonable care in the operation and maintenance of the products as described in the owner's manual(s); d) repairs requiring overtime, weekend rates, or anything beyond the standard manufacturer warranty repair labor reimbursement rate; e) time required for any security checks, safety training, or similar for service personnel to gain access to facility; and f) location of unit must have adequate clearance for service personnel to perform repairs and easily accessible.

### WHAT IS NOT COVERED

This warranty does not cover normal wear and tear or any malfunction, failure, or defect resulting from misuse, abuse, neglect, alteration, modification, or repair by other than a service center authorized by the manufacturer to repair this air compressor. Expendable materials, such as motor brushes, seals, etc. are not covered by this warranty. This warranty does not apply to this compressor used in industrial applications or for rental purposes. Husky makes no warranties, representations, or promises as to the quality or performance of its air compressors other than those specifically stated in this warranty.

**Implied warranties, including those of merchantability and fitness for a particular purpose, are limited to two years from the date of original purchase by the consumer.** Any incidental, indirect, or consequential loss, damage, or expense that may result from any defect, failure, or malfunction of the manufacturer's product is not covered by this warranty. Some states do not allow the exclusion or limitations of incidental or consequential damages, so the above limitation or exclusion may not apply to you. The warranty does not cover any failure that results from an accident, purchaser's abuse, neglect, or failure to operate products in accordance with instructions provided in the owner's manual(s) supplied with compressor.

This warranty does not cover pre-delivery service, i.e. assembly, oil or lubricants, and adjustment. This warranty does not cover items or service that is normally required to maintain the product, i.e. lubricants, filters, gaskets, etc.

Gasoline engines and components are expressly excluded from coverage under this limited warranty. The purchaser must comply with the warranty given by the engine manufacturer which is supplied with the product.

The following items not covered under this warranty. This warranty excludes these items (pertaining to all compressors) as follows: a) any component damaged in shipment or any failure caused by installing or operating unit under conditions not in accordance with installation and operation guidelines or damaged by contact with tools or surroundings; b) pump or valve failure caused by rain, excessive humidity, corrosive environments, or other contaminants; c) cosmetic defects that do not interfere with compressor functionality; d) rusted tanks, including but not limited to rust due to improper drainage or corrosive environments; e) any components that are considered normal wear items and are not covered after the first year of ownership [the electric motor, check valve, pressure switch, regulator, pressure gauges, hose, tubing, pipe, fittings and couplers, screws, nuts, hardware items, belts, pulleys, flywheel, air filter and housing, gaskets, seals, oil leaks, air leaks, oil consumption or usage, piston rings]; f) the tank drain valves; g) damage due to incorrect voltage or improper wiring; h) other items not listed but considered general wear parts; i) pressure switches, air governors, load/unload devices, throttle control devices, and safety valves modified from factory settings; j) damage from inadequate filter maintenance; and k) induction motors operated with electricity produced by a generator.

The following items not covered under this warranty. This warranty excludes these items (specific to lubricated compressors) as follows: a) pump wear or valve damage caused by using oil not specified; b) pump wear or damage caused by any oil contamination; and c) pump wear or damage caused by failure to follow proper oil maintenance guidelines, operation below proper oil level, or operation without oil.

Labor, service calls, or transportation charges after the first year of ownership are not covered on stationary air compressors. Stationary air compressors are defined as those units not including a handle or wheels.

This Limited Warranty applies in the U.S., Canada, and Mexico only. This warranty gives you specific legal rights, and you may also have other rights which vary from state to state.

How to get service: Call 1-888-43-HUSKY or visit [www.HUSKYTOOLS.com](http://www.HUSKYTOOLS.com).

# Pre-Installation

## PLANNING INSTALLATION



**WARNING:** Disconnect, tag, and lock out the power source before attempting to install or relocate the compressor.

## TOOLS REQUIRED

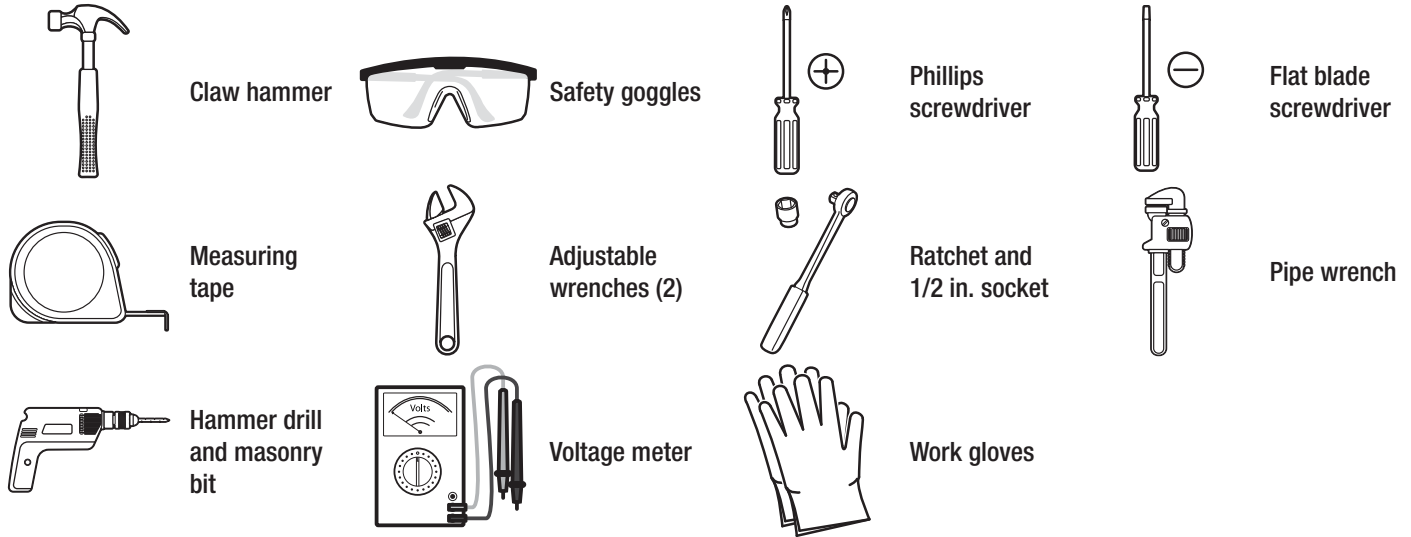

## HARDWARE INCLUDED



**NOTE:** Hardware not shown to actual size.

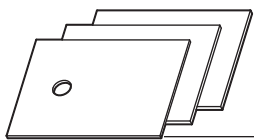

AA



BB



CC

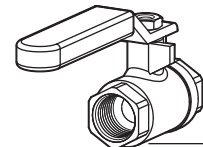

DD

Part	Description	Quantity
AA	Vibration isolation set (3 metal plates and 6 rubber pads)	3 sets
BB	Reducer	1
CC	Nipple	1
DD	Shut-off valve	1

## HARDWARE REQUIRED



**NOTE:** Hardware not shown to actual size.

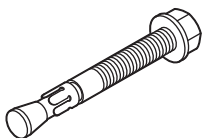

Concrete wedge anchors

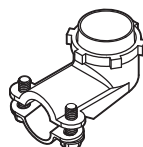

Strain relief



Thread sealant tape

# Pre-Installation

## PACKAGE CONTENTS

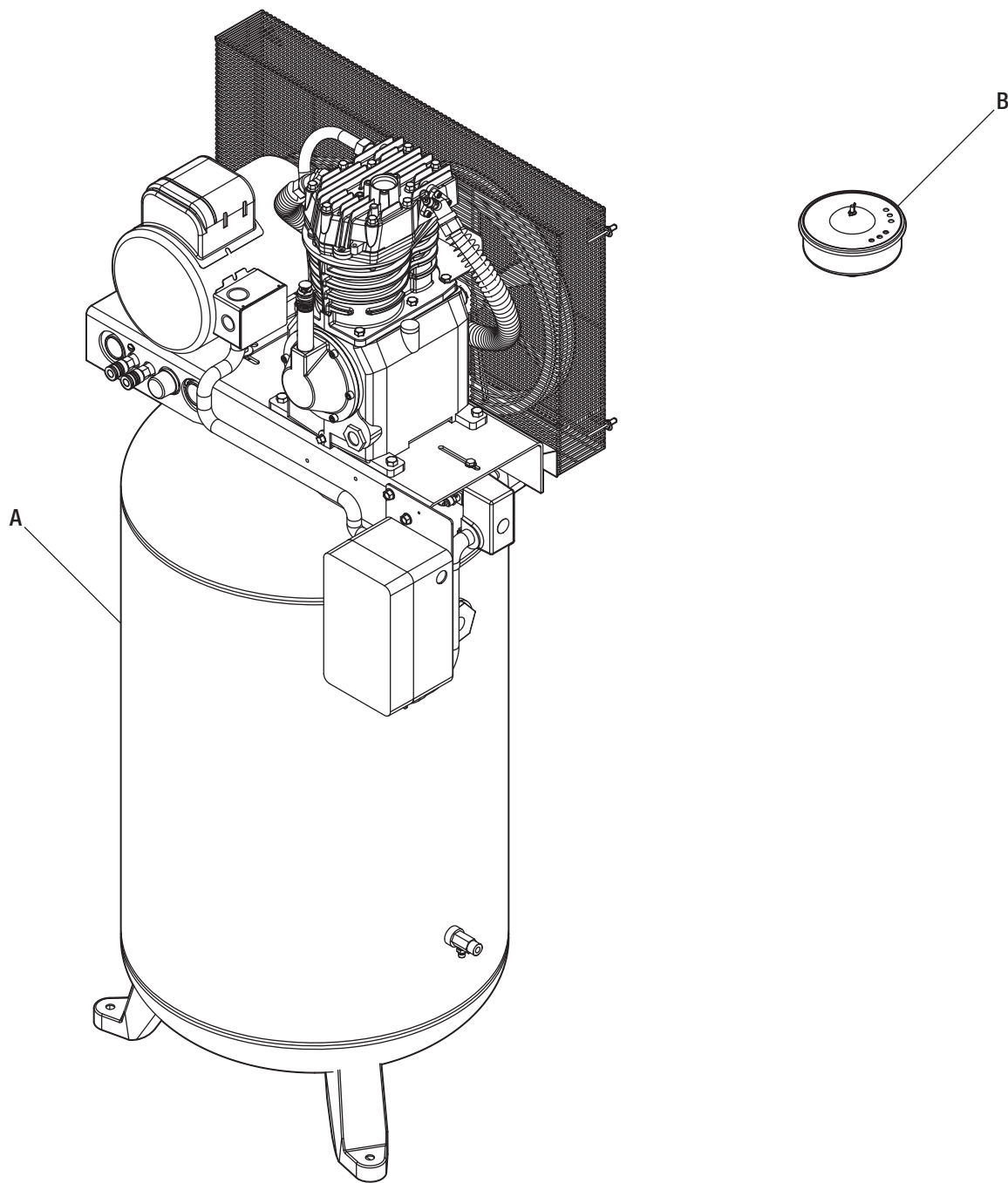

Part	Description	Quantity
A	Air Compressor Unit	1
B	Air Filter Assembly	1



# Pre-Installation

## COMPRESSOR COMPONENTS

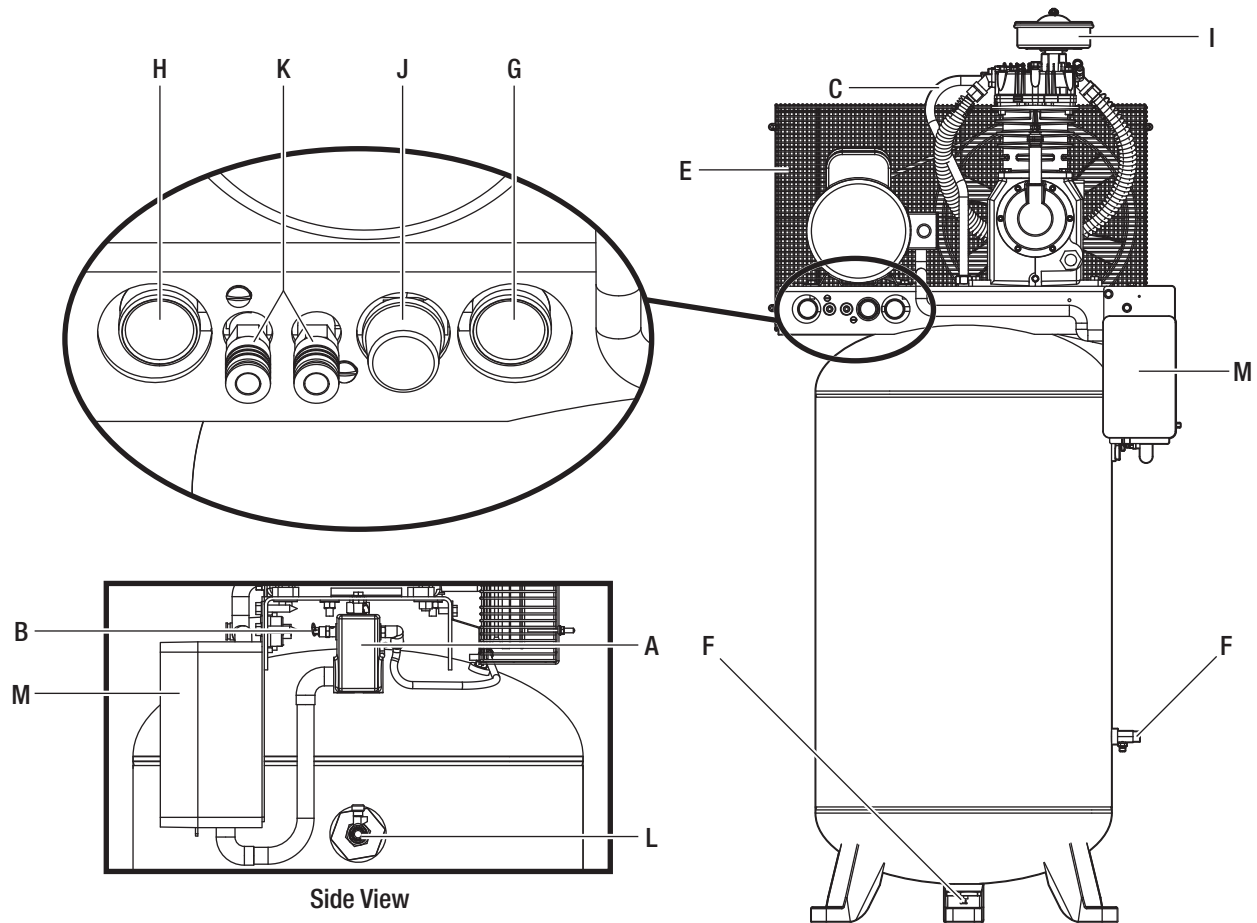

Part	Description
A	<b>Pressure Switch</b> - The compressor shuts off automatically when the tank pressure reaches the maximum preset pressure. After air is used from the tank and drops to a preset low level, the pressure switch signals the magnetic starter to turn the motor back on. When the motor turns off, you will hear air leaking out of the pressure switch unloader valve for a short time. This releases the air pressure from the discharge tube and allows the compressor to restart easier.
B	<b>ASME Safety Valve</b> - This valve automatically releases air if the tank pressure exceeds the preset maximum.
C	<b>Discharge Tube</b> - This tube carries compressed air from the pump to the check valve. This tube becomes very hot during use. To avoid the risk of severe burns, never touch the discharge tube.
D	<b>Check Valve (not visible)</b> - One-way valve that allows air to enter the tank, but prevents air in the tank from flowing back into the compressor pump.
E	<b>Belt Guard</b> - Covers the belt, motor pulley, and flywheel.
F	<b>Drain Valve</b> - Use this valve to drain moisture from the tank daily to reduce the risk of corrosion.
G	<b>Tank Pressure Gauge</b> - Indicates the amount of air pressure stored in the tank.
H	<b>Outlet Pressure Gauge</b> - Indicates the amount of air pressure being delivered out the discharge port.
I	<b>Air Filter</b> - Keeps large particulates out of the air flowing into the compressor.
J	<b>Regulator</b> - Controls the amount of air pressure released at the discharge port.
K	<b>Universal Coupler</b> - A direct connect to the air compressor unit for use of air hose(s).
L	<b>Discharge Port</b> - Air delivery port for transfer of compressed air.
M	<b>Magnetic Starter</b> - Controls the start and stop of the motor based on the signal from the pressure switch.

## Pre-Installation (continued)

### SPECIFICATIONS

<b>Horsepower (HP)</b>	7.5
<b>Number of Cylinders</b>	2
<b>Voltage</b>	230/240 Volts, 31 Amps 60 Hz, 1 Phase
<b>Air Delivery @ 175 psi</b>	22.2 SCFM
<b>Air Delivery @ 90 psi</b>	23.7 SCFM
<b>Max. Air Pressure</b>	175 psi

<b>Tank Outlet Size</b>	3/4 NPT
<b>Oil Capacity</b>	approximately 2 quarts
<b>Length</b>	29 in.
<b>Width</b>	33 in.
<b>Height</b>	77 in.
<b>Weight</b>	540 lbs.

# Installation - Mounting

## 1 Preparing for installation



**WARNING:** Disconnect, tag, and lock out the power source, and then release all pressure from the system before attempting to install, service, relocate, or perform any maintenance.



**WARNING:** This compressor is extremely top heavy. Enlist additional help to remove it from the shipping skid.



**CAUTION:** Never use the shipping skid for mounting the compressor.



**IMPORTANT:** Provide a minimum clearance of 18 in. between the compressor flywheel or fan and the wall, and ensure clear access to the drain valve to facilitate condensate drainage.



**IMPORTANT:** It is extremely important to install the compressor in a clean, well ventilated area where the surrounding air temperature will not be more than 100°F.



**IMPORTANT:** Do not locate the compressor air inlet near steam, paint spray, sandblast areas, or any other source of contamination.



**IMPORTANT:** This compressor is not intended for outdoor installation.

- Unbolt the air compressor unit (A) from the shipping skid. Use a ratchet with a 1/2 in. socket.
- Remove the air compressor unit (A) from the skid. This requires at least two people - one person to “walk” the unit off the skid and one to help maintain balance so the unit does not topple. Place the air compressor unit (A) where you plan to install it (at least 18 in. from any wall or surface).

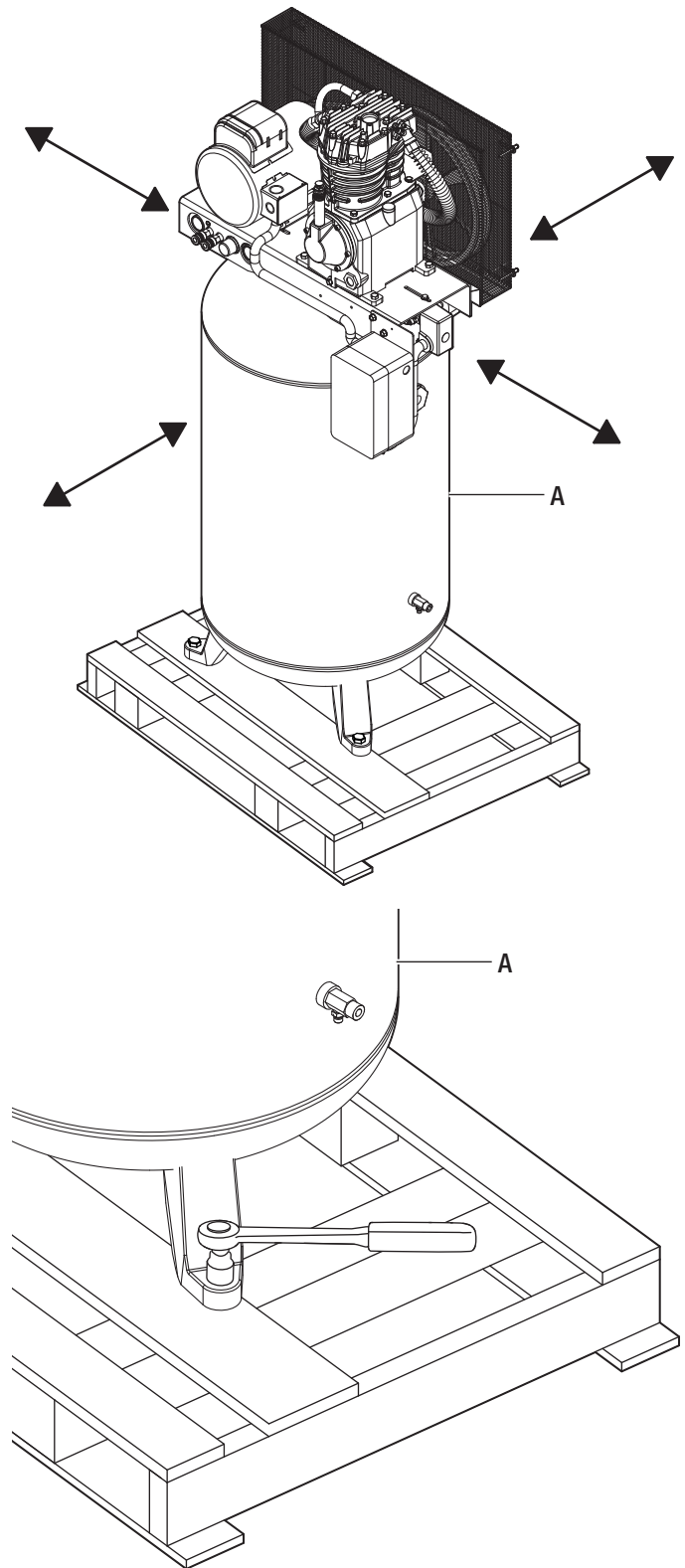

## Installation - Mounting (continued)

### 2 Drilling the mounting holes



**WARNING:** This compressor is extremely top heavy. The unit must be bolted to the floor with isolation pads before operating to prevent equipment damage, injury, or death.

- Place the pre-drilled vibration pads (AA) under each air compressor unit (A) foot to avoid unnecessary vibration which could damage the air compressor unit (A).
- Using the mounting holes and the holes of the vibration pads (AA) as a guide, drill holes into the concrete using a 3/8 in. masonry bit. Holes drilled must be at least as deep as the concrete wedge anchors being used.

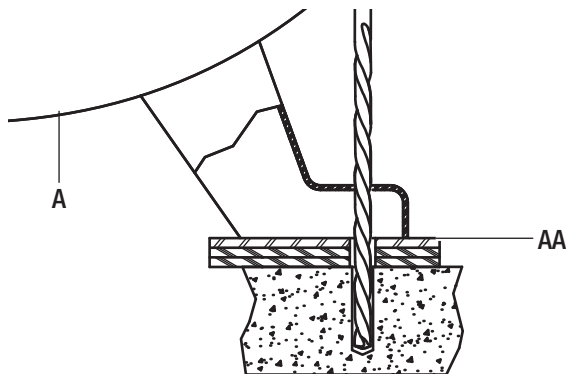

### 3 Inserting the mounting bolts

- Insert the mounting bolts into the drilled holes.
- Place a washer on each bolt. Thread a nut onto each bolt until the top of the nuts and bolts are flush.
- Strike the bolt heads with a hammer until the nuts and washers are sitting on top of the air compressor unit (A) foot.

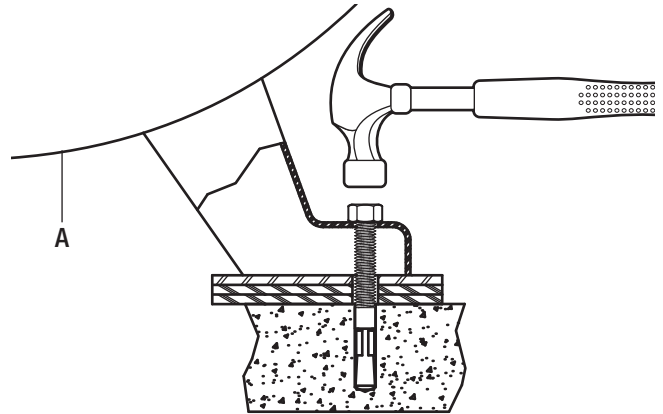

### 4 Setting the mounting bolts

- Tighten the nuts using a ratchet with a 9/16 in. socket until the anchors are set.
- Use the installation torque specifications of the bolt (provided by the bolt manufacturer).
- Loosen the nuts to leave a 1/16 in. (1.6 mm) gap for stress relief during the air compressor unit (A) operation.

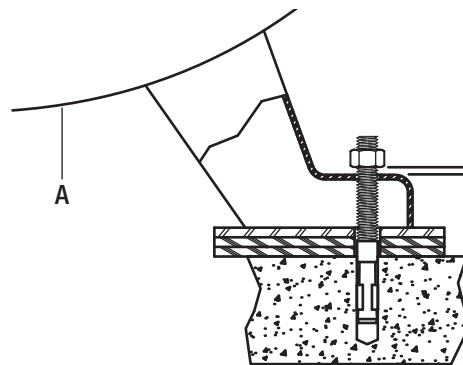
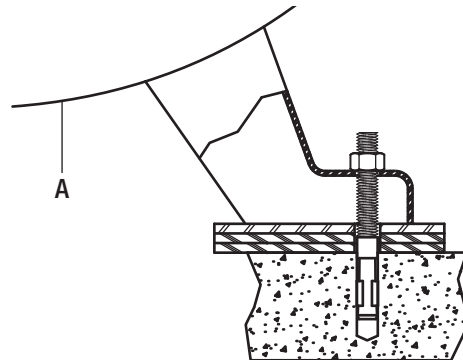

# Installation - Electrical

## 1 Preparing for installation



**DANGER:** Improperly grounded motors are shock hazards. Make sure all the equipment is properly grounded.



**WARNING:** All wiring and electrical connections must be performed by a qualified electrician familiar with industrial motor controls. Installations must be in accordance with local and national codes.



**WARNING:** Disconnect, tag, and lock out the power source, and then release all pressure from the system before attempting to install, service, relocate, or perform any maintenance.



**WARNING:** Overheating, short circuiting, and fire damage will result from inadequate wiring.



**IMPORTANT:** Damage to the motor from improper electrical voltage or connection will void the warranty.

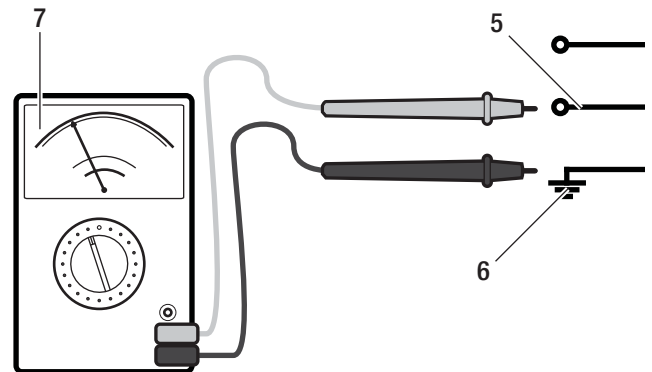
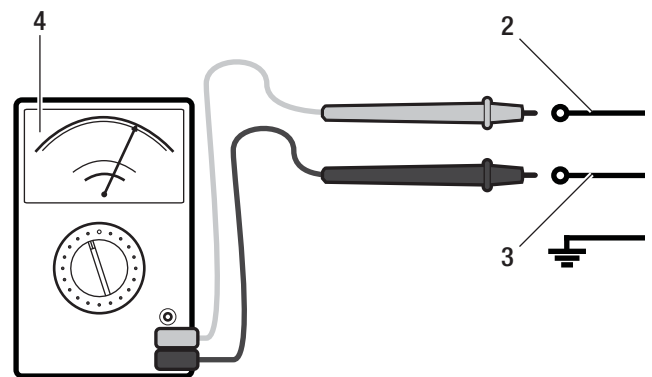
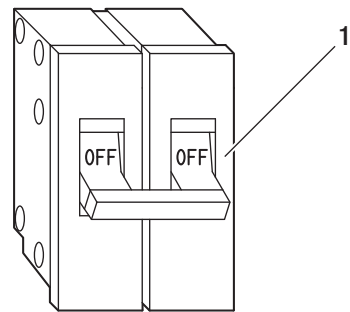

This product must be grounded. If the unit comes with a factory installed cord, plug the cord into a properly sized, grounded outlet. For units that do not have a factory installed cord, install permanent wiring from the electrical source to the pressure switch with a ground conductor connected to the grounding screw on the pressure switch. A properly sized cord with a ground conductor and plug may also be installed by the user.

Local electrical wiring codes differ from area to area. Source wiring and protector must be rated for at least the amperage and voltage indicated on the motor nameplate, and meet all electrical codes for this minimum. The minimum wire size should also meet all electrical codes, and wiring used up to 75 ft. long must be 10 AWG. Use a slow blow fuse type T or a 240-Volt double-pole circuit breaker (1).

- Confirm the voltage of the incoming mains (2,3) using a voltage meter (4).
- The voltage meter should read 230/240 Volts. Do not proceed with installation if the voltage meter gives a different reading.
- Confirm the voltage of the incoming mains (5) and ground wire (6) using a voltage meter (7).
- The voltage meter should read 120 Volts. Do not proceed with installation if the voltage meter gives a different reading.

## Installation - Electrical (continued)

### 2 Preparing the magnetic starter

- Remove the magnetic starter cover by loosening the screw (1), as shown. Use a Phillips screwdriver.
- Lift the cover upwards from the bottom and off the base.
- Set the cover aside until wiring is completed.
- Familiarize yourself with these internal components of the magnetic starter.
- Refer to the illustration below to identify the ground wire (2) from pressure switch, ground screw (3), wires from pressure switch (4), wires from motor (5), thermal overload (6), and terminal screws (7).

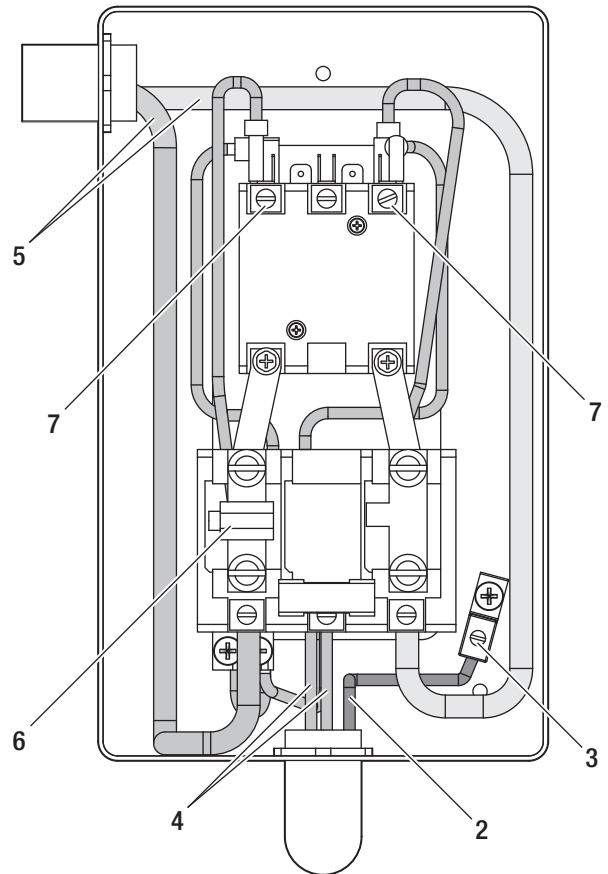
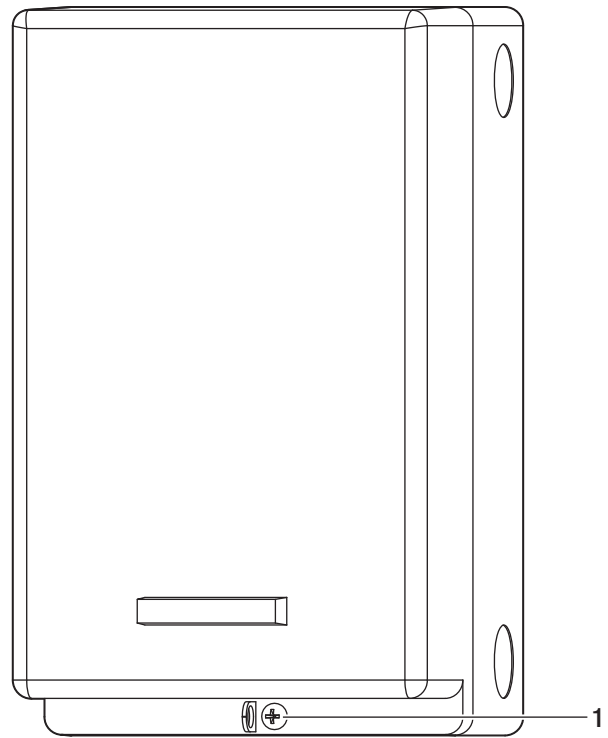

## Installation - Electrical (continued)

### 3 Making the electrical connections

- Use a blunt tool and hammer to carefully tap out the stamped cover (1) at the top of the magnetic starter box (2).
- Loosen the ground screw (3). Loosen the terminal screws (4).
- Install the strain relief (5) on the magnetic starter (2). Do not tighten the screws (6) or nut (7) of the strain relief (5) on the power cord until wiring is complete.
- Insert the bare wires [black, red, bare/green](8, 9, 10) through the strain relief (5).
- Attach the bare/green ground wire (10) first to the ground screw (3) on the magnetic starter body.
- Install the line wires (8, 9) and tighten the terminal screws (4).

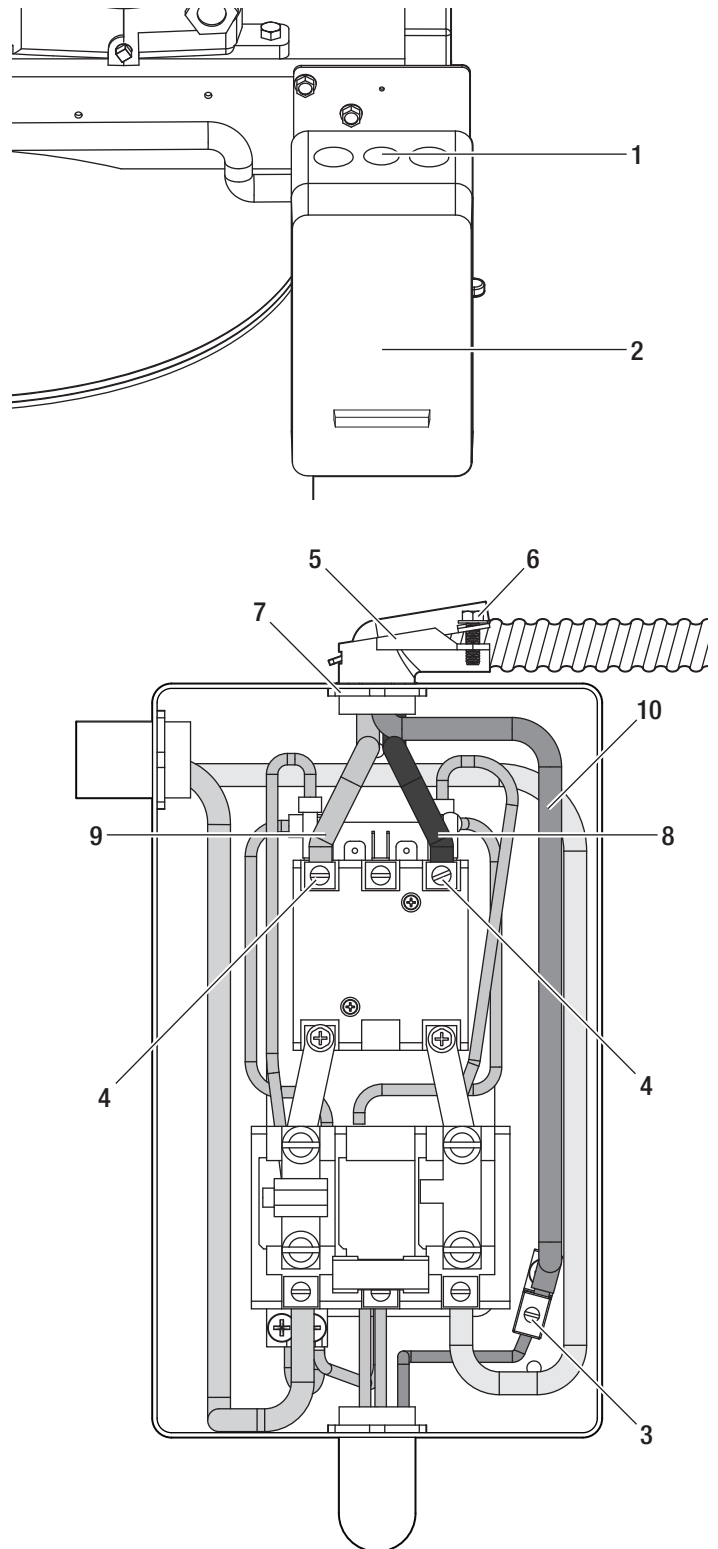

## Installation - Electrical (continued)

### 4 Securing the strain relief

- Tighten the strain relief nut (1). Place a flathead screwdriver into the raised notch, and tap the screwdriver with a hammer until tight.
- Tighten the strain relief screws (2) to hold the power cord securely.

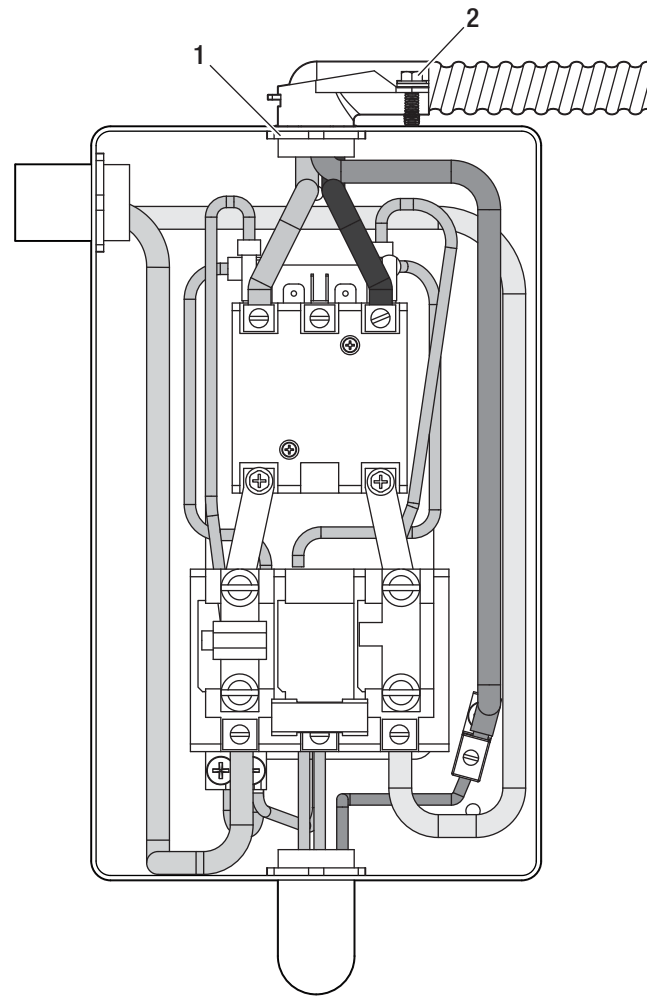

### 5 Reinstalling the magnetic starter cover

- Replace the magnetic starter cover.
- Tighten the magnetic cover screw (1) with a Phillips screwdriver. Follow the break-in procedure from the owner's manual.

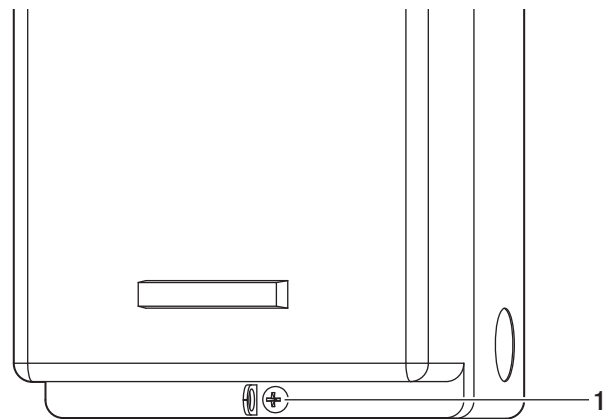



# Assembly

## 1 Assembling the air compressor unit



**WARNING:** Never use plastic (PVC) pipe for compressed air. Serious injury or death could result.



**WARNING:** Never install a shut-off valve between the compressor pump and the tank. Personal injury and/or equipment damage may occur. Never use reducers in discharge piping.



**NOTE:** Do not overtighten. Over the life of the unit, you will clean or replace the filter as needed.

This air compressor unit can be installed as part of an air distribution system. Any tube, pipe, or hose used in an air distribution system must have a pressure rating higher than 175 psi. The minimum recommended pipe size is 3/4 in. Using a larger diameter pipe is always better.

Use thread sealant tape on all the threaded connections of the air compressor unit (A). This will prevent any air leaks between the assembled parts.

- ❑ Screw the air filter (B) onto the pump air intake.
- ❑ Install the provided reducer (BB) into the discharge port of the tank.
- ❑ Attach the nipple (CC) to the reducer (BB).
- ❑ Connect the shut-off valve (DD) to the nipple (CC).

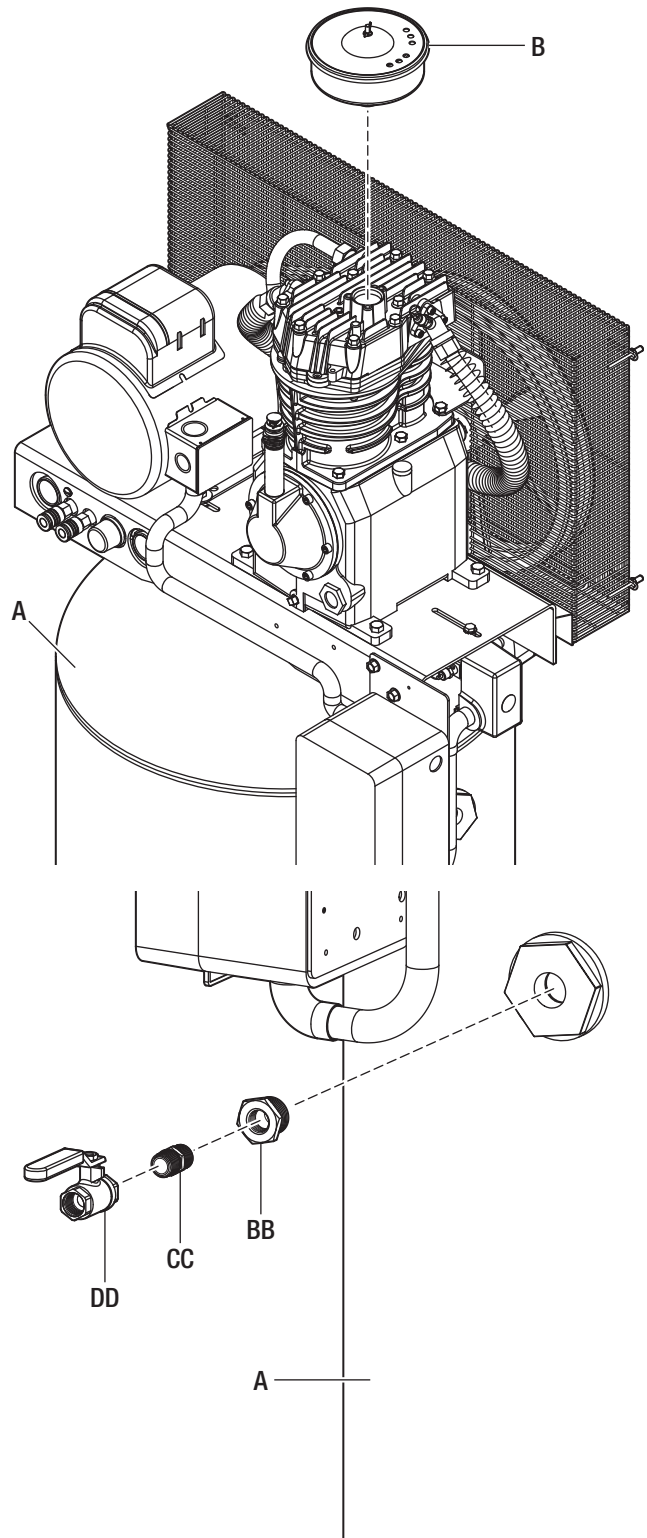

# Operation

## 1 Preparing for use



**CAUTION:** Check for proper oil level before operating!



**NOTE:** The pump oil level is full (1) as shown.



**NOTE:** Use SAE 30 industrial grade air compressor oil or full synthetic motor oil like Mobil 1® 10W30.



**NOTE:** Do not exceed the maximum oil capacity of approximately 2 qts.



**NOTE:** Do not use regular automotive oil. Additives in regular motor oil can cause valve deposits and reduce pump life.



**NOTE:** For maximum pump life, drain and replace oil after the first hour of run time.

- Use the sight glass on the pump to determine the oil level.
- Add oil to the pump if the oil level is low (2).

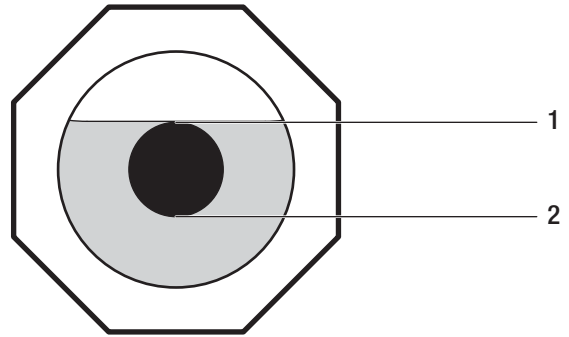

## 2 Starting-up and breaking-in the compressor



**WARNING:** Do not attach air tools to the open end of the hose until start-up is completed and the unit checks okay.



**WARNING:** Never disconnect threaded joints with pressure in the tank!

- Open the tank drain valve. The tank will not readily buildup any pressure.
- Return power to the air compressor unit (A) from the main.
- Run the air compressor unit (A) for thirty (30) minutes at zero (0) psi (under no load) to break-in the pump parts.
- Turn power off to the air compressor unit (A) from the main. Close the tank drain valve to shut off air flow. The air compressor unit (A) is now ready for use.

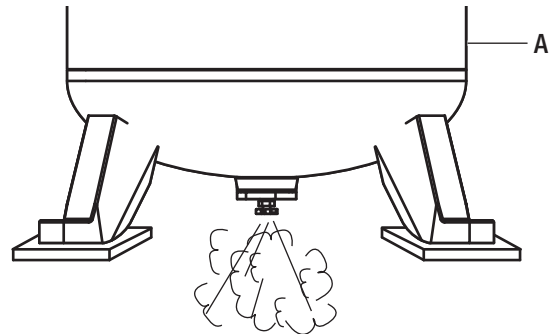

# Operation (continued)

## ON/OFF CYCLING OF THE COMPRESSOR

The air compressor unit (A) is designed to cycle on and off. When the shut-off (preset “cut-out”) pressure is reached, the compressor automatically shuts off.

When air is depleted from the tank by use of a tire chuck, tool, etc., the compressor will restart automatically at its preset “cut-in” pressure. When a tool is in use, the compressor will cycle on and off automatically as needed to maintain air pressure in the tank.

## MAGNETIC STARTER



**CAUTION:** Repeated overloads can cause damage to the motor and void the product warranty.

The magnetic starter is a large relay that switches high current from the main power line in response to a signal from the pressure switch. The starter also has a device to protect the electric motor against overheating due to overcurrent. This protection is accomplished by heater elements that become hot in response to the motor current. The heaters are sized so that overcurrent causes them to interrupt power to the section of the starter controlling motor current, turning the motor off. After the heater elements cool, reset the starter to resume operation.

In normal operation, the starter requires no attention. If an overload occurs, follow the thermal overload reset instructions in the Maintenance section of this manual.

## MOISTURE IN COMPRESSED AIR



**WARNING:** Drain the tank every day to prevent corrosion and possible injury due to tank damage. For optimal performance of the tank drain, the tank pressure should be between 10 - 50 psi. Do not operate the drain with more than 40 psi in the tank or the drain valve may be damaged. Drain the tank of moisture daily using the drain valve in the side of the tank or at the bottom of the tank.



**IMPORTANT:** This condensation will cause water spots in a paint job, especially when spraying other than water based paints. If sandblasting, it will cause the sand to cake and clog the gun, rendering it ineffective. A filter in the air line, located as near to the gun as possible, will help eliminate this moisture.



**IMPORTANT:** Drain liquid from the tank daily.

Moisture in compressed air will form into droplets as it comes from an air compressor pump. When humidity is high or when a compressor is in continuous use for an extended period of time, this moisture will collect in the tank. When using a paint spray or sandblast gun, this water will be carried from the tank through the hose, and out of the gun as droplets mixed with the spray material.

Follow the tank draining instructions in the Maintenance section of this manual.

# Maintenance

## GENERAL MAINTENANCE

All repairs should be performed by an authorized service representative.



**WARNING:** Disconnect, tag, and lock out the power source, and then release all pressure from the system before attempting to install, service, relocate, or perform any maintenance.

## 1 Checking and changing the oil

Maintain the proper oil level by checking the oil sight glass (1) daily. Change the oil in the pump every 3 months. Use the following procedure to change (or add) oil.

- Run the compressor for ten minutes to warm up the oil if the unit has not been in use for an extended period of time.
- Turn the compressor off and disconnect the compressor from the power source.
- Position a pan under the pump drain plug (2) to catch the oil.
- Remove the pump drain plug (2) and allow the oil to collect in the pan.
- Reinsert the oil drain plug. Remove the oil fill plug (3). Pour new, unused oil into the pump. Do not overfill.
- Reinsert the oil fill plug (3) into position. Return power to the compressor for use.

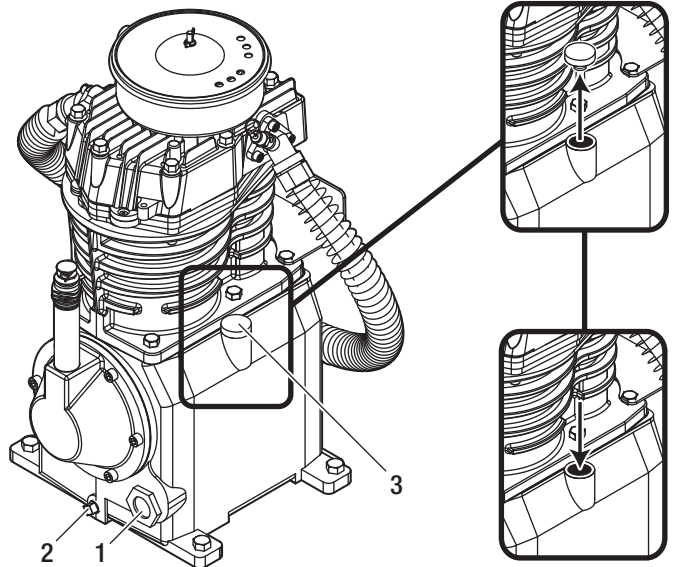

## 2 Checking the ASME safety valve

- Run the air compressor until it reaches cut-out pressure.
- Turn the compressor off and disconnect the compressor from the power source.
- Put on safety glasses. Protect yourself from fast moving air.
- Pull on the ring of the ASME safety valve (1). This releases pressure from the tank. The safety valve should automatically close at approximately 40 - 50 psi.

If the safety valve does not allow air to be released when you pull on the ring, or if it does not close automatically, it **MUST** be replaced.

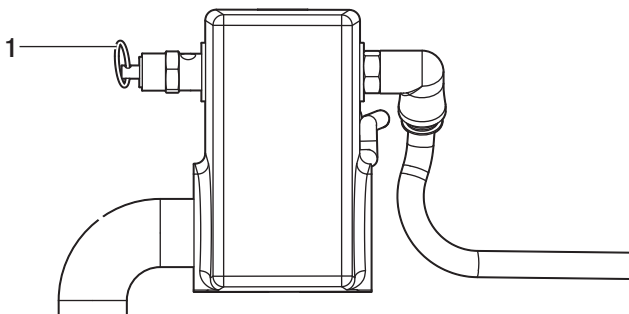

## 3 Draining the tank of moisture

- Turn the compressor off and disconnect it from the power source.
- Release the pressure from the compressor by pulling on the ASME safety valve. The ASME safety valve should close at approximately 40 - 50 psi.
- Open the drain valve (1) underneath the tank. Remaining air pressure will assist in removing moisture from the tank.

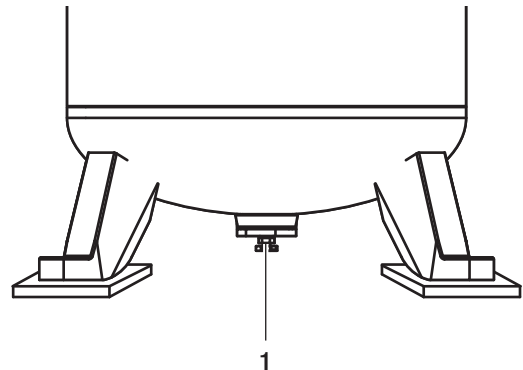

## Maintenance (continued)

### 4 Checking the belt

- Remove the four caps (1) and four flange nuts (2).
- Remove the front beltguard (3).
- Pull the front beltguard (3) away from the air compressor unit (A).
- If the belt appears to be in working order and has no signs of damage, return the front beltguard (3) to the original position.
- Tighten the flange nuts (2) and reinstall the caps (1).
- If the belt needs to be replaced, move on to the next step.

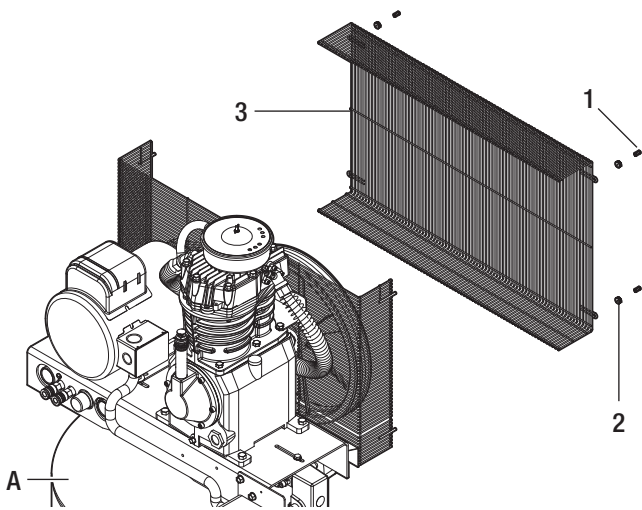

### 5 Removing the belt

- Loosen (but do not remove) the four bolts (1) holding the motor in place.
- Shift the motor towards the pump. The belt should be slack and easily removed.
- Replace the belt.
- Move the motor back to the original position to create belt tension.
- Tighten the motor bolts.

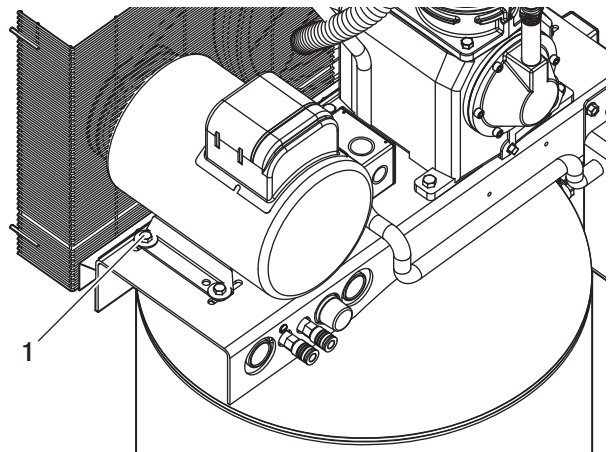

### 6 Aligning/tensioning the belt

- Lay a straightedge (1) against the face of the flywheel touching the rim at two places (2,3).
- Adjust the flywheel or motor pulley so that the belt (4) runs parallel to the straightedge. Use a gear puller to move the pulley on the motor shaft. Tighten the setscrew after the pulley is positioned.
- Adjust the motor's distance from the pump if needed.
- Belt tension is determined by how much the belt moves when weight is applied. The belt should move no more than 3/8 to 1/2 in. downward if normal thumb pressure is placed on it.
- Tighten the motor bolts once the proper belt tension is achieved.
- Reattach the belt guard.

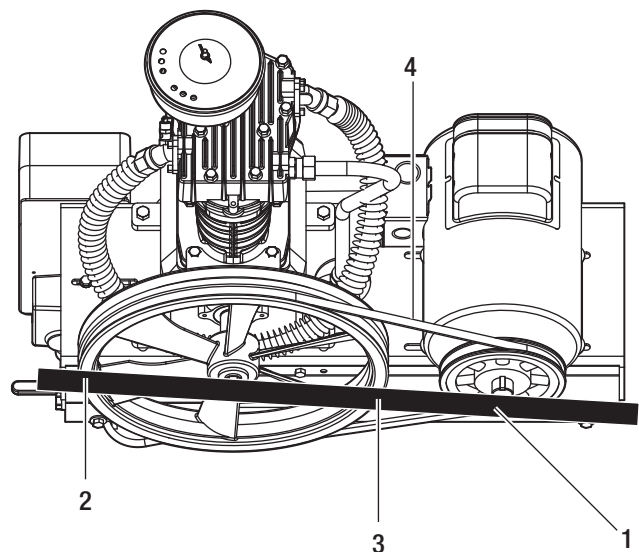

## Maintenance (continued)

### 7 Resetting the thermal overload

Allow the air compressor unit (A) to cool down after thermal overload of the magnetic starter is tripped.

- Disconnect, tag, and lock out the power source for the air compressor unit (A).
- Push the external reset switch (1). The internal overload switch (2) will be pushed back into place and return contact for the electrical current.
- Return power to the air compressor unit (A).

If the air compressor unit (A) does not return to normal operation, other maintenance may be required.

- Disconnect, tag, and lock out the power source for the air compressor unit (A).
- Remove the magnetic starter cover by loosening the screw (3), as shown. Use a Phillips screwdriver.
- Lift the cover upwards from the bottom and off the base. Set the cover aside.
- Remove the internal overload switch (2) and replace. Contact Husky Customer Service at 1-888-43-HUSKY for assistance.

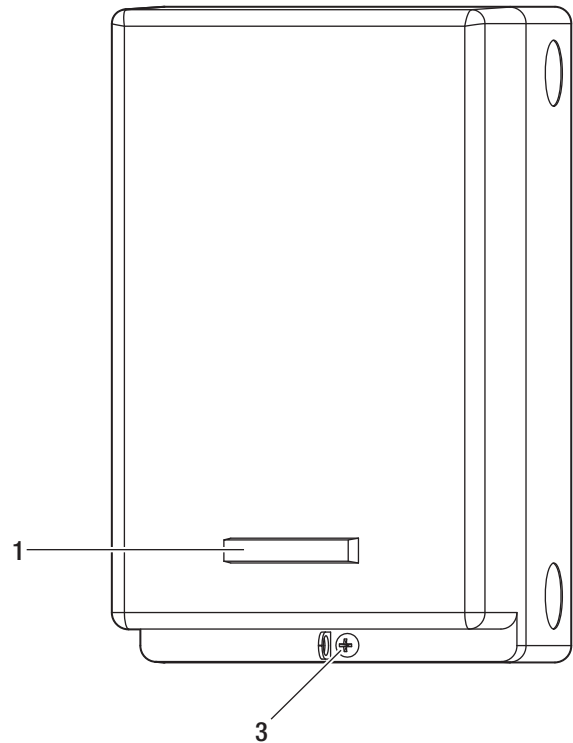

### THERMAL OVERLOAD CAUSES

In normal operation, the starter requires no attention. If an overload occurs, the compressor motor will not restart, even when the tank pressure drops. It is important to find the cause of the overload and correct it. Overloads can be caused by one of the following:

1. **Pressure setting too high:** Check to make sure the pressure switch opens at or before the maximum rated operating pressure of the air compressor unit. If the pressure switch fails to operate correctly, contact Husky Customer Service at 1-888-43-HUSKY for assistance.
2. **Low voltage condition:** Voltage at the motor terminals must be within 10% of the rated voltage during start-up and while the motor is running. Have a qualified electrician check this and correct it as needed.
3. **Loose connections or open fuse:** Loose connections or blown fuses cause high currents in the remaining wires of the circuit. Have a qualified electrician check and correct these conditions.
4. **Unloader valve or check valve malfunction:** The motor will overload if it starts against the air trapped in the discharge tube. Replace valves that are not working correctly. Contact Husky Customer Service at 1-888-43-HUSKY for assistance.

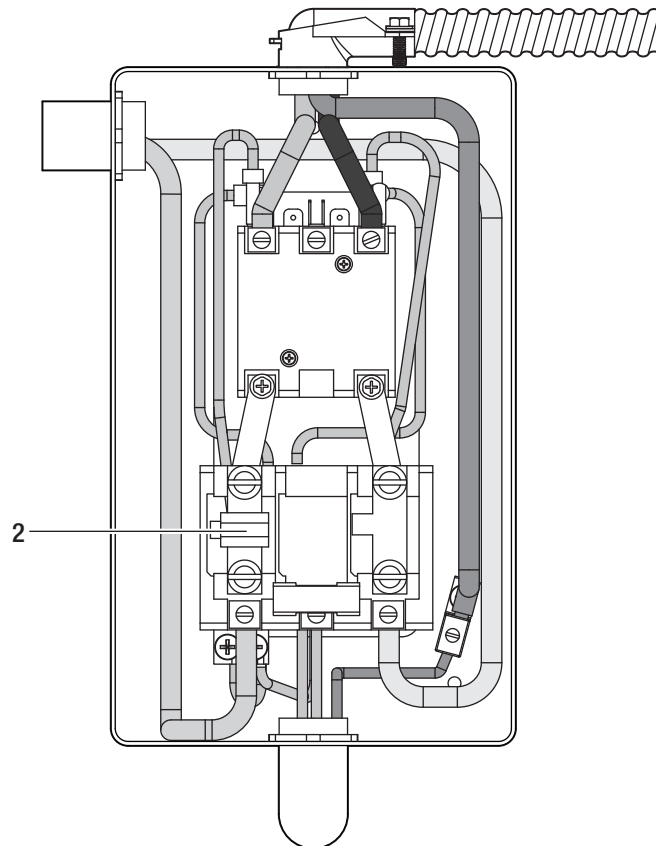

## Maintenance (continued)

### 8 Checking the air filter

- Remove the nut (1).
- Remove the air filter cover (2) from the air filter base (4).
- Remove and inspect the air filter element (3).
- If the air filter element is dirty, replace it. Install a new filter element. If the air filter element is clean, reinstall it.
- Reattach the air filter cover (2).
- Reattach the nut (1). Do not overtighten the nut as this maintenance process will be repeated regularly. The nut (1) should be snug enough to hold the air filter cover (2) in place.

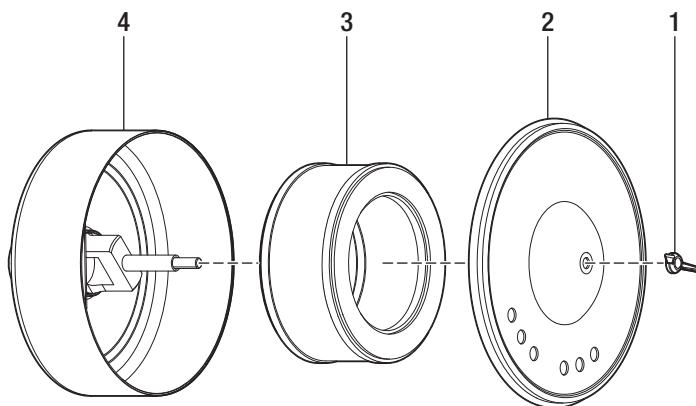

### MAINTENANCE SCHEDULE



**WARNING:** Disconnect, tag, and lock out the power source, and then release all pressure from the system before attempting to install, service, relocate, or perform any maintenance.

Operation	Daily	Weekly	Monthly	Every 3 Months
Check Oil Level	X			
Drain Tank	X			
Check Air Filter		X		
Check Safety Valve		X		
Clean Unit			X	
Check Belt Tension			X	
Change Oil				X



**IMPORTANT:** Change oil after the first fifty (50) hours of operation. Then perform oil changes every three (3) months.

### Care and Cleaning



**WARNING:** Disconnect, tag, and lock out the power source, and then release all pressure from the system before attempting to install, service, relocate, or perform any maintenance.

- Keep all surfaces clear of debris and dirt.
- Do not attempt to clean the unit while running. Turn off the unit, disconnect it from the mains, and allow the unit to cool down.
- Check the air filter weekly to see if it needs to be cleaned. Remove the filter element. Use hot, soapy water to clean the filter and allow the filter to dry before reinstalling and returning the unit to active duty. Replace a filter that cannot be cleaned.

# Troubleshooting

Problem	Possible Cause	Solution
The discharge pressure is low.	<ul style="list-style-type: none"> <li><input type="checkbox"/> The air demand exceeds the pump capacity.</li> <li><input type="checkbox"/> The air intake is restricted.</li> <li><input type="checkbox"/> There are air leaks in the fittings, tubing on the compressor, or the plumbing outside the unit.</li> <li><input type="checkbox"/> There are blown gaskets.</li> <li><input type="checkbox"/> There are leaking or damaged valves.</li> </ul>	<ul style="list-style-type: none"> <li><input type="checkbox"/> Reduce the air demand or use a compressor with more capacity.</li> <li><input type="checkbox"/> Clean or replace the air filter element.</li> <li><input type="checkbox"/> Listen for escaping air. Apply soap solution to all fittings and connections. Bubbles will appear at points of leakage. Tighten or replace leaking fittings or connections. Use pipe thread sealant.</li> <li><input type="checkbox"/> Replace any gaskets proven faulty on inspection.</li> <li><input type="checkbox"/> Remove the head and inspect for valve breakage, misaligned valves, damaged valve seats, etc. Replace defective parts and reassemble. Install a new head gasket each time the head is removed.</li> </ul>
The pump is overheating and causing the air filter to melt.	<ul style="list-style-type: none"> <li><input type="checkbox"/> The insulating gasket between the filter and the head is missing.</li> <li><input type="checkbox"/> There are broken valves/blown gaskets.</li> </ul>	<ul style="list-style-type: none"> <li><input type="checkbox"/> Install the gasket.</li> <li><input type="checkbox"/> Replace the valves or install the new gasket.</li> </ul>
The air compressor unit is making excessive noise (a knocking sound).	<ul style="list-style-type: none"> <li><input type="checkbox"/> The motor pulley or the flywheel is loose.</li> <li><input type="checkbox"/> The fasteners on the pump or the motor are loose.</li> <li><input type="checkbox"/> There is no oil in the crankcase.</li> <li><input type="checkbox"/> The connecting rod is worn.</li> <li><input type="checkbox"/> The piston pin bores are worn.</li> <li><input type="checkbox"/> The piston is hitting the valve plate.</li> <li><input type="checkbox"/> There is a noisy check valve in the compressor system.</li> </ul>	<ul style="list-style-type: none"> <li><input type="checkbox"/> Tighten the pulley/flywheel clamp bolts and the set-screws.</li> <li><input type="checkbox"/> Tighten the fasteners.</li> <li><input type="checkbox"/> Check for proper oil level; if the oil level is low, check for possible damage to the bearings. Dirty oil can cause excessive wear.</li> <li><input type="checkbox"/> Replace the connecting rod. Maintain the oil level and change the oil more frequently.</li> <li><input type="checkbox"/> Remove the piston assemblies from the compressor and inspect for excess wear. Replace the excessively worn piston pin or pistons, as required. Maintain the oil level and change the oil more frequently.</li> <li><input type="checkbox"/> Remove the compressor head and the valve plate and inspect for carbon deposits or other foreign matter on the top of the piston. Replace the head and the valve plate using the new gasket. See the Lubrication section for the recommended oil type.</li> <li><input type="checkbox"/> Replace the check valve. Do not disassemble the check valve with air pressure in the tank.</li> </ul>
There is a large quantity of oil in the discharge air. <b>NOTE:</b> In an oil lubricated compressor there will always be a small amount of oil in the air stream.	<ul style="list-style-type: none"> <li><input type="checkbox"/> The piston rings are worn.</li> <li><input type="checkbox"/> The compressor's air intake is restricted.</li> <li><input type="checkbox"/> There is excessive oil in the compressor.</li> <li><input type="checkbox"/> The oil viscosity is wrong.</li> </ul>	<ul style="list-style-type: none"> <li><input type="checkbox"/> Replace with new rings. Maintain the oil level and change the oil more frequently.</li> <li><input type="checkbox"/> Clean or replace the filter. Check for other restrictions in the intake system.</li> <li><input type="checkbox"/> Drain oil down to the correct full level.</li> <li><input type="checkbox"/> Only use Mobil 1® 10W-30.</li> </ul>
There is water in discharge air/tank.	<ul style="list-style-type: none"> <li><input type="checkbox"/> This is normal during operation. The amount of water increases with humid weather.</li> </ul>	<ul style="list-style-type: none"> <li><input type="checkbox"/> Drain the tank more often. At least daily.</li> <li><input type="checkbox"/> Add a filter to reduce the amount of water in the air line.</li> </ul>
The pressure switch does not release air when the unit shuts off.	<ul style="list-style-type: none"> <li><input type="checkbox"/> The unloader valve on the pressure switch is malfunctioning.</li> </ul>	<ul style="list-style-type: none"> <li><input type="checkbox"/> Replace the unloader valve if it does not release the pressure for a short period of time when the unit shuts off. Do not disassemble the check valve with air pressure in the tank.</li> </ul>



## Troubleshooting (continued)

Problem	Possible Cause	Solution
The motor hums and runs slowly, or the motor does not run at all.	<ul style="list-style-type: none"> <li><input type="checkbox"/> The voltage is low.</li> <li><input type="checkbox"/> There are too many devices on the same circuit.</li> <li><input type="checkbox"/> The electrical connections are loose.</li> <li><input type="checkbox"/> The pressure switch is malfunctioning - the contacts will not close.</li> <li><input type="checkbox"/> The check valve is malfunctioning.</li> <li><input type="checkbox"/> The unloader valve on the pressure switch is defective.</li> <li><input type="checkbox"/> The motor capacitor(s) are defective.</li> <li><input type="checkbox"/> The motor is defective.</li> </ul>	<ul style="list-style-type: none"> <li><input type="checkbox"/> Check incoming voltage. It should be approximately 240 volts. The motor will not run properly on 208 volts. Low voltage could be due to wires (from electrical source to compressor) being too small in diameter and/or too long. Have a qualified electrician check these conditions and make repairs as needed.</li> <li><input type="checkbox"/> Limit the circuit to the use of the compressor only.</li> <li><input type="checkbox"/> Check all the electrical connections.</li> <li><input type="checkbox"/> Replace the pressure switch.</li> <li><input type="checkbox"/> Replace the check valve. Do not disassemble the check valve with air pressure in the tank.</li> <li><input type="checkbox"/> Replace the unloader valve.</li> <li><input type="checkbox"/> Replace the capacitor(s).</li> <li><input type="checkbox"/> Replace the motor.</li> </ul>
The reset mechanism cuts out repeatedly or the circuit breaker trips repeatedly.	<ul style="list-style-type: none"> <li><input type="checkbox"/> There is not proper ventilation for the air compressor unit, or the room temperature too high.</li> <li><input type="checkbox"/> There are too many devices on the same circuit.</li> <li><input type="checkbox"/> The air intake is restricted.</li> <li><input type="checkbox"/> The electrical connections are loose.</li> <li><input type="checkbox"/> The pressure switch shut-off pressure is set too high.</li> <li><input type="checkbox"/> The check valve is malfunctioning.</li> <li><input type="checkbox"/> The unloader valve on the pressure switch is defective.</li> <li><input type="checkbox"/> The motor capacitor(s) are defective.</li> <li><input type="checkbox"/> The motor is defective.</li> </ul>	<ul style="list-style-type: none"> <li><input type="checkbox"/> Move the compressor to a well-ventilated area.</li> <li><input type="checkbox"/> Limit the circuit to the use of only the air compressor.</li> <li><input type="checkbox"/> Clean or replace the air filter element.</li> <li><input type="checkbox"/> Check all the electrical connections.</li> <li><input type="checkbox"/> Replace the pressure switch.</li> <li><input type="checkbox"/> Replace the check valve. Do not disassemble the check valve with air pressure in the tank.</li> <li><input type="checkbox"/> Replace the unloader valve.</li> <li><input type="checkbox"/> Replace the capacitor(s).</li> <li><input type="checkbox"/> Replace the motor.</li> </ul>
The tank does not hold pressure when the compressor is off and the shut off valve is closed.	<ul style="list-style-type: none"> <li><input type="checkbox"/> There are air leaks in the fittings, tubing on the compressor, or the plumbing outside the unit.</li> <li><input type="checkbox"/> The check valve is worn.</li> <li><input type="checkbox"/> Check the tank for cracks or pin holes.</li> </ul>	<ul style="list-style-type: none"> <li><input type="checkbox"/> Listen for escaping air. Apply soap solution to all fittings and connections. Bubbles will appear at points of leakage. Tighten or replace leaking fittings or connections. Use pipe thread sealant.</li> <li><input type="checkbox"/> Replace the check valve. Do not disassemble the check valve with air pressure in the tank.</li> <li><input type="checkbox"/> Replace the tank. Never try to repair a damaged tank.</li> </ul>
The pressure switch continuously blows air out of the unloader valve.	<ul style="list-style-type: none"> <li><input type="checkbox"/> The check valve is malfunctioning.</li> </ul>	<ul style="list-style-type: none"> <li><input type="checkbox"/> Replace the check valve if the unloader valve on the pressure switch bleeds off constantly when the unit shuts off. Do not disassemble the check valve with air pressure in the tank.</li> </ul>
There is excessive vibration.	<ul style="list-style-type: none"> <li><input type="checkbox"/> The fasteners on the pump or the motor are loose.</li> <li><input type="checkbox"/> The belt needs to be replaced.</li> <li><input type="checkbox"/> The belt needs to be aligned.</li> </ul>	<ul style="list-style-type: none"> <li><input type="checkbox"/> Tighten the fasteners.</li> <li><input type="checkbox"/> Replace the belt. Make sure to use the correct size.</li> <li><input type="checkbox"/> Align the flywheel and the pulley.</li> </ul>

## Troubleshooting (continued)

Problem	Possible Cause	Solution
The motor hums and runs slowly or not at all.	<ul style="list-style-type: none"> <li><input type="checkbox"/> The voltage supplied to the air compressor unit is low or not present.</li> <li><input type="checkbox"/> The motor winding is shorted or open.</li> <li><input type="checkbox"/> The check valve or the unloader valve is malfunctioning.</li> <li><input type="checkbox"/> The pressure switch is malfunctioning and the contacts will not close.</li> </ul>	<ul style="list-style-type: none"> <li><input type="checkbox"/> Check the incoming voltage with a voltmeter. Check the overload relay in magnetic starter or the reset switch on the motor. If the overload or the reset switch trips repeatedly, find and correct the cause.</li> <li><input type="checkbox"/> Replace the motor.</li> <li><input type="checkbox"/> Replace the check valve or the unloader valve.</li> <li><input type="checkbox"/> Repair or replace the pressure switch.</li> </ul>
The oil in the oil reservoir of the pump is milky.	<ul style="list-style-type: none"> <li><input type="checkbox"/> Water is condensing in the crankcase due to high humidity.</li> </ul>	<ul style="list-style-type: none"> <li><input type="checkbox"/> Pipe the air intake to a less humid air source. Then run the air compressor unit (A) continuously under no load for one hour. Open the drain valve to prevent the air compressor unit from building pressure.</li> </ul>
There is excessive oil consumption or oil in the air lines of the air compressor unit (A).	<ul style="list-style-type: none"> <li><input type="checkbox"/> The air intake is restricted.</li> <li><input type="checkbox"/> The oil in the pump is the wrong type or viscosity.</li> <li><input type="checkbox"/> The piston rings are worn.</li> <li><input type="checkbox"/> Oil leaks out of the pump.</li> <li><input type="checkbox"/> The cylinder is scored or damaged.</li> </ul>	<ul style="list-style-type: none"> <li><input type="checkbox"/> Clean or replace the air filter.</li> <li><input type="checkbox"/> Drain the air compressor unit (A) of oil. Refill with new oil of the proper viscosity.</li> <li><input type="checkbox"/> Replace the piston rings.</li> <li><input type="checkbox"/> Tighten the bolts, replace the gaskets or replace the o-rings of the pump.</li> <li><input type="checkbox"/> Replace the cylinder of the pump.</li> </ul>
The air compressor unit (A) builds up pressure quickly.	<ul style="list-style-type: none"> <li><input type="checkbox"/> There is excessive water in the tank.</li> </ul>	<ul style="list-style-type: none"> <li><input type="checkbox"/> Drain the tank.</li> </ul>
Interstage safety valve pops off when the unit is running.	<ul style="list-style-type: none"> <li><input type="checkbox"/> Valve problem or worn gasket.</li> <li><input type="checkbox"/> Low head bolt torque.</li> <li><input type="checkbox"/> Defective interstage safety valve.</li> </ul>	<ul style="list-style-type: none"> <li><input type="checkbox"/> Check and replace valve or gaskets.</li> <li><input type="checkbox"/> Check and retighten head bolts to specified torque.</li> <li><input type="checkbox"/> Replace interstage safety valve. Under no circumstances plug the safety valve port.</li> </ul>



# Service Parts - Compressor

MODEL TF291204

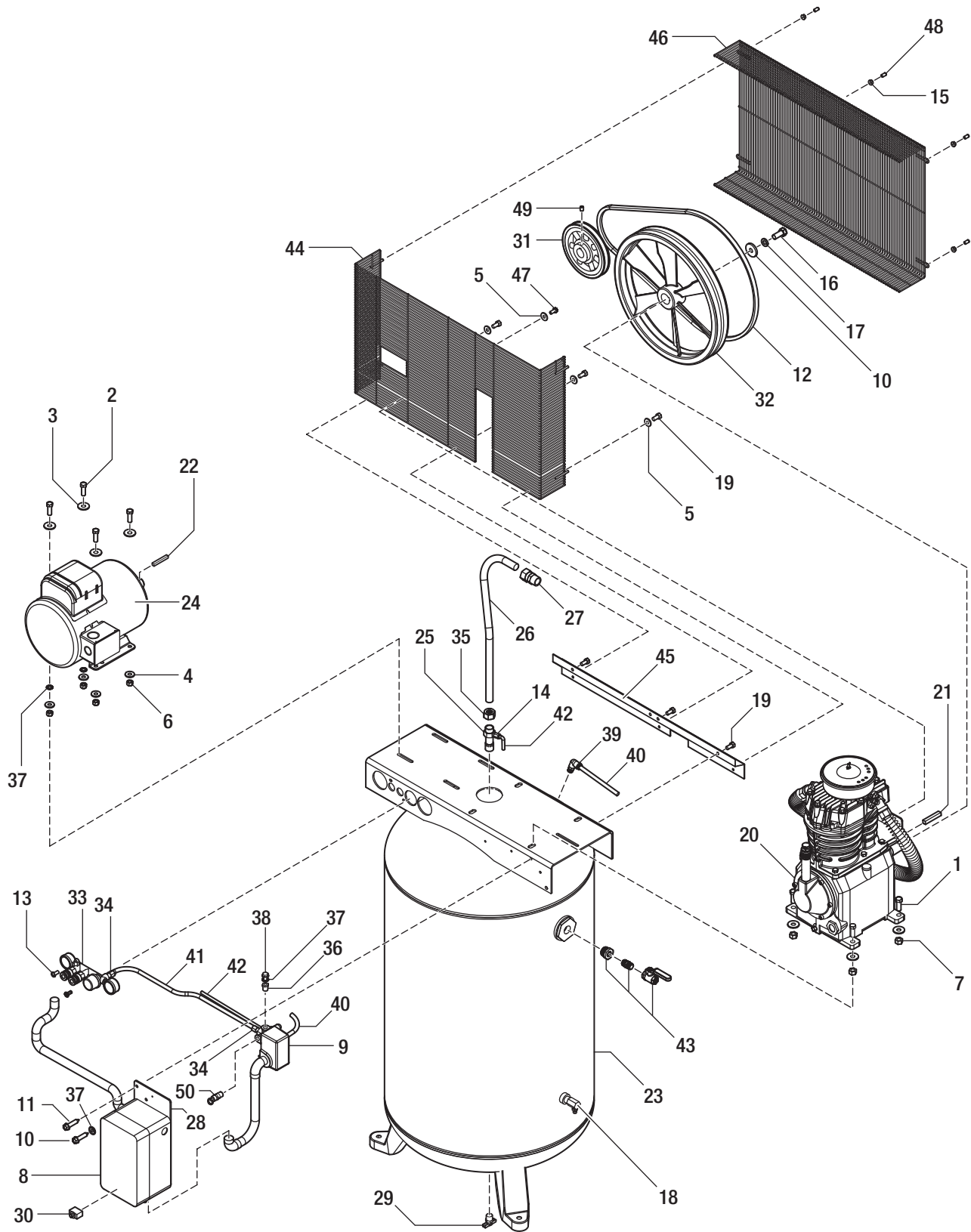

## Service Parts - Compressor (continued)

Part	Description	Part Number	Qty
1	Hex head cap screw, 7/16 - 14 x 1-1/2	ST070645AV	4
2	Hex head cap screw, 3/8 - 16 x 1-1/4	ST070638AV	4
3	Washer, 7/16	ST070916AV	8
4	Washer, 3/8	ST070914AV	4
5	Washer, 5/16	ST011200AV	4
6	Flange nut, 3/8 - 16	ST033500AV	4
7	Hex nut, 7/16 - 14	--	4
8	Magnetic starter	ST122010AJ	1
9	Pressure switch	CW218000AV	1
10	Flywheel washer	TX034600AV, ◆	1
11	Self tapping screw, 5/16 - 12 x 3/4	ST016500AV	8
12	Belt	BT010601AV	1
13	Button torx screw, 1/4 - 20 x 1/2	ST071626AV	2
14	Tube fitting	ST081301AV	1
15	Hex flange nut, 10 - 24	ST116201AV	1
16	Hex head screw, 1/2 - 13 UNC x 1-1/4	◆	1
17	Lock washer	◆	1
18	Side drain assembly	D-140501AV	1
19	Hex tapping screw, 5/16 - 12 x 3/4	ST073221AV	6
20	Pump	XP7101	1
21	Square key	KE001310AV	1
22	Square key	--	1
23	Tank	AR210300CG	1
24	Motor	MC025100AV	1
25	Check valve	CV003404AV	1
26	Exhaust tube	XP080000AP	1
27	Compression fitting	ST072024AJ	1
28	Magnetic starter bracket	BG215300AV	1
29	Drain valve	D-1403	1
30	Thermal overload switch	PS005554AV	1
31	Pulley	PU009799AV	1
32	Flywheel with key	FP070041AV	1
33	Manifold assembly	WL021100AV	1
34	Push fitting	ST119305AV	2
35	Compression nut	ST072321AV	1

Part	Description	Part Number	Qty
36	Plug	ST187200AV	1
37	External tooth lock washer	ST072608AV	4
38	5/16 Flange head bolt	ST187300AV	1
39	Push connect	ST119704AV	2
40	Tube, pressure switch to tank	WL005900AV	1
41	Tube, pressure switch to control panel	WL021410AV	1
42	Unloader tube	ST117802AV	1
43	Shut off valve assembly	PA117000AV	1
44	Beltguard, back	BG221200AV	1
45	Beltguard bracket	XP050700AV	1
46	Beltguard, front	BG221100AV	1
47	Self tapping screw, 1/4 - 20	ST074415AV	1
48	Screw cap	ST075400AV	4
49	Set screw	--	1
50	Safety valve, 200 psi ASME	V-215200AV	1
51	Unloader valve (pressure switch, not shown)	CW210001AV	1
--	Not available		
<b>REPLACEMENT PARTS KITS</b>			
◆	Flywheel bolt kit	FP070040AV	

# Service Parts - Pump

MODEL XP7101

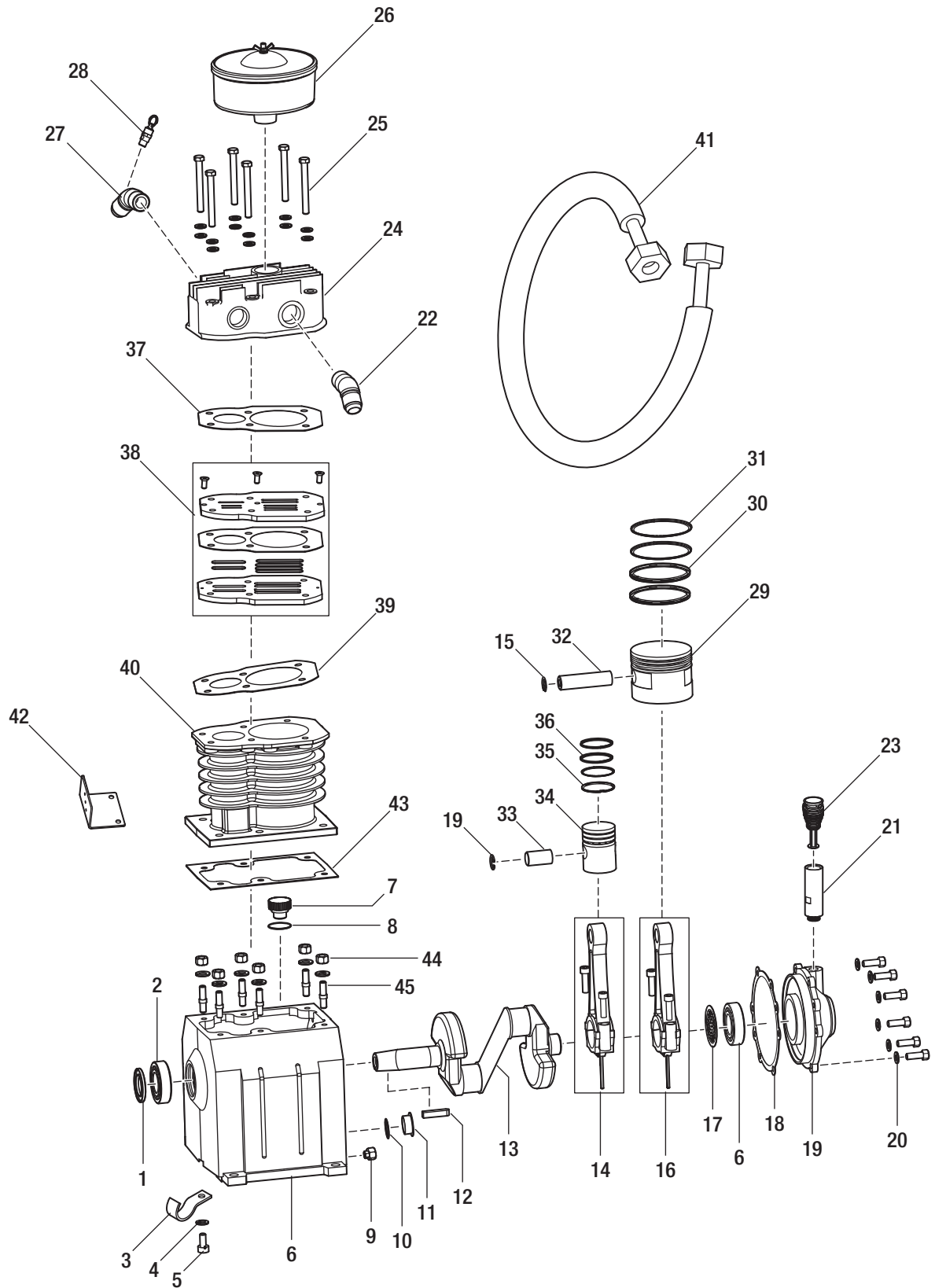

## Service Parts - Pump (continued)

Part	Description	Part Number	Qty
1	Oil seal	FP070042AV ◆ ⊗	1
2	Ball bearing	●	2
3	Cooler bracket	--	1
4	Washer	⊕	1
5	Bracket fixing bolt	⊕	1
6	Crankcase	--	1
7	Fill plug	✕	1
8	Fill plug o-ring	✕ ⊗	1
9	Drain plug	--	1
10	Oil level gauge o-ring	▼ ⊗	1
11	Oil level gauge	▼	1
12	Key	■	1
13	Crankshaft	●	1
14	High pressure connecting rod assembly	FP070047AV	1
15	Wrist pin retainer	□ ○	2
16	Low pressure connecting rod assembly	FP070048AV	1
17	Baffle	♣	1
18	Bearing cap packing	⊗	1
19	Bearing cap	♣	1
20	Brass washer, M10	⊕	12
21	Breather tube assembly	FP070075AV	1
22	Intercooler fitting without tapped hole	FP070053AV	1
23	Breather assembly	FP070070AV	1
24	Cylinder head	FP070054AV	1
25	Head bolts, M10 - 1.5 x 100	⊕	6
26	Air filter housing with filter element	DP500056AV	1
27	Intercooler fitting with tapped hole	FP070058AV	1
28	1/8 in. NPT Safety valve, 72.5 psi	V-208900AV	1
29	Low pressure piston	□	1
30	Low pressure oil control ring	△	2
31	Low pressure compression ring	△	2

Part	Description	Part Number	Qty
32	Low pressure piston pin	□	1
33	High pressure piston pin	○	1
34	High pressure piston	○	1
35	High pressure oil control ring	◇	1
36	High pressure compression ring	◇	3
37	Cylinder head packing	▽ ⊗	1
38	Valve assembly	▽	1
39	Valve-cylinder packing	▽ ⊗	1
40	Cylinder	FP070065AV	1
41	Intercooler assembly with flare nuts	FP070066AV	1
42	Beltguard bracket	FP070059AV	1
43	Cylinder-crankcase packing	⊗	1
44	Nut, M10	⊕	6
45	Cylinder stud, M10 x 40	⊕	1
46	Air filter element (D5 type) [not shown]	HS050071AV	1
47	Air filter element (X5 type) [not shown]	ST073903AV	1

### REPLACEMENT PARTS KITS

●	Crankshaft assembly with bearings	FP070043AV	
▼	Oil level gauge with o-ring	DP400045AV	
✕	Oil cap with o-ring	FP070046AV	
♣	Bearing cap with baffle	FP070050AV	
△	Piston ring kit (low pressure)	FP070060AV	
□	Piston set (low pressure)	FP070061AV	
○	Piston set (high pressure)	FP070062AV	
◇	Piston ring kit (high pressure)	FP070063AV	
▽	Valve plate kit	FP070064AV	
⊗	Gasket, oil seal, and o-ring kit (except valve plate to plate gasket)	FP070068AV	
⊕	Assembly fastener set	FP070069AV	
--	Not available		



Questions, problems, missing parts? Before returning to the store,  
call Husky Customer Service  
8 a.m.-6 p.m., EST, Monday-Friday

**1-888-43-HUSKY**

**HUSKYTOOLS.COM**

Retain this manual for future use.

Document Number IN564900AV 7/13