

Specifications and Features
Spécifications et Caractéristiques
Especificaciones y Características

MXS21001

Address parts correspondence to: Parts Department
Correspondance: 100 Production Drive
Puede escribirnos a: Harrison, OH 45030 U.S.A

Please provide following information:

- Model number
- Stamped-in code
- Part description and number as shown in parts list

S'il vous plaît fournir l'information suivante:

- Numéro du modèle
- Code Estampé
- Description et numéro de la pièce

Sírvase darnos la siguiente información:

- Número del modelo
- Número de Serie o código con fecha (de haberlo)
- Descripción y número del repuesto según la lista de repuestos

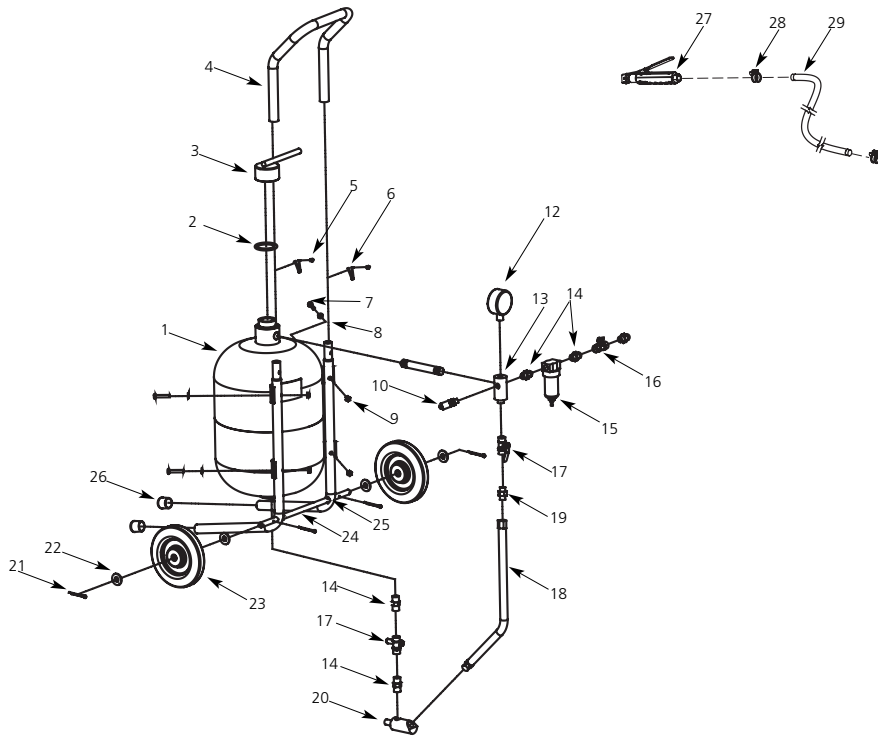

Specifications and Features
Spécifications et Caractéristiques
Especificaciones y Características

MXS21001

Replacement Parts List

Ref. No.	Description	Part No.	Qty.
1	Hopper, 45 lb.	-	1
2	O-ring	-	1
3	Hopper cap	-	1
4	Handle	-	1
5	Pin	-	1
6	Spring	-	1
7	Screw, M6 x 30	*	1
8	Flat washer, M6	*	1
9	Hex nut, M6	*	1
10	Safety valve	HF226100AV	1
11	Tube	SV942200AV	1
12	Pressure gauge	BC412400AV	1
13	Air manifold	SV941800AV	1
14	Brass nipple, 3/8"	MP213600AV	1
15	Filter	PA400000AV	1
16	Pressure release ball valve	HF226000AV	2
17	Shutoff ball valve	PA113600AV	1
18	Air hose	-	1
19	Brass nipple, 3/8", 37° flare	-	1
20	Material manifold	SV941900AV	1
21	Cotter pin - M4 x 40 mm	*	1
22	Flat washer (M6)	*	1
23	Wheels	-	1
24	Wheel axle	SV942100AV	1
25	Axle bracket	-	1
26	Rubber boot	-	1
27	Pressure blast gun	MXS40004	1
28	Hose clamp	*	2
29	Hose, 8-ft.	SV942000AV	1

* Standard hardware item

www.maxustools.com

Liste de Pièces de Rechange

N° de Réf.	Description	N° de Pièce	Qté.
1	Trémie de 20,4 kg (45 lb)	-	1
2	Joint torique	-	1
3	Couvercle de trémie	-	1
4	Manche	-	1
5	Goupille	-	1
6	Ressort	-	1
7	Vis, M6 x 30	*	1
8	Rondelle plate, M6	*	1
9	Écrou hexagonal (hex.), M6	*	1
10	Soupape de sécurité	HF226100AV	1
11	Tube	SV942200AV	1
12	Manomètre	BC412400AV	1
13	Collecteur d'air	SV941800AV	1
14	Raccord de laiton, 3/8"	MP213600AV	1
15	Filtre	PA400000AV	1
16	Soupape à bille pour dissiper la pression	HF226000AV	2
17	Soupape d'arrêt à bille	PA113600AV	1
18	Tuyau à air	-	1
19	Mamelon de laiton, 9,53 mm (3/8 po), évasement de 37°	-	1
20	Collecteur de matériel	SV941900AV	1
21	Goupille tendue - M4 x 40 mm	*	1
22	Rondelle plate, M6	*	1
23	Roue	-	1
24	Arbre de roue	SV942100AV	1
25	Support d'arbre	-	1
26	Fourreau en caoutchouc	-	1
27	Pistolet de décapage à pression	MXS40004	1
28	Collier de serrage	*	2
29	Tuyau, 2,44m	SV942000AV	1

* Article normal de quincaillerie