

Needle Scaler

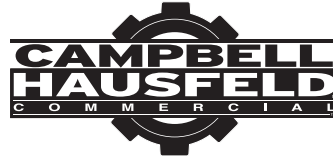

MODEL: CL158101AV

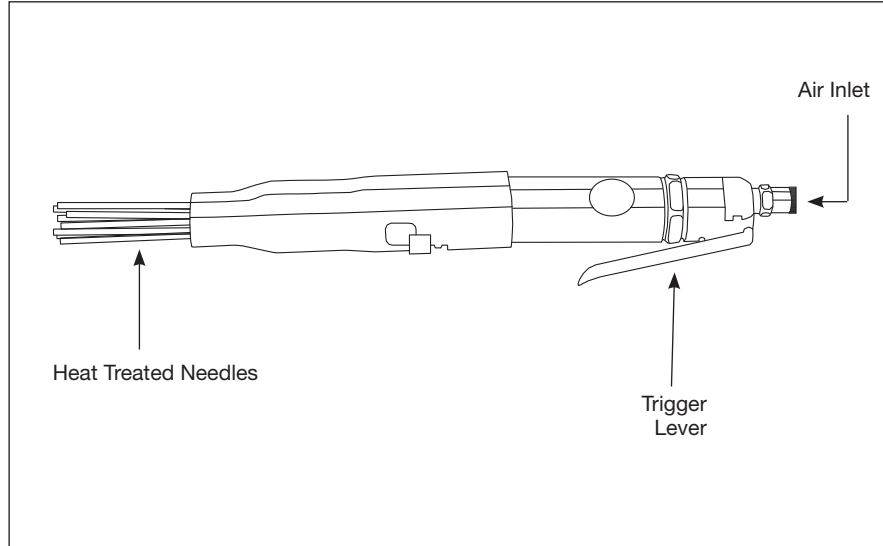

Description

In-line needle scalers are designed to remove flux build-up from welds.

Specifications

Rated Blows per Minute	4,000
Average Air Consumption	8.6 SCFM @ 90 psig (45% usage)
Continuous Air Consumption	19.2 SCFM @ 90 psig (100% usage)
Max. Operating Pressure	90 psig
Stroke Length	3/8 inches (9.5 mm)
Needle Quantity	19
Needle Size	1/8 inch
Air Inlet	1/4 inch NPT (Female)
Minimum Hose Size	3/8 inch
Weight	6.0 lbs.

**For Replacement Parts or Technical Assistance,
Call 1-855-504-5678**

Please provide following information:

- Model number
- Serial number (if any)
- Part description and number as shown in parts list

Address any correspondence to:

Campbell Hausfeld
Attn: Customer Service
100 Production Drive
Harrison, OH 45030 U.S.A.

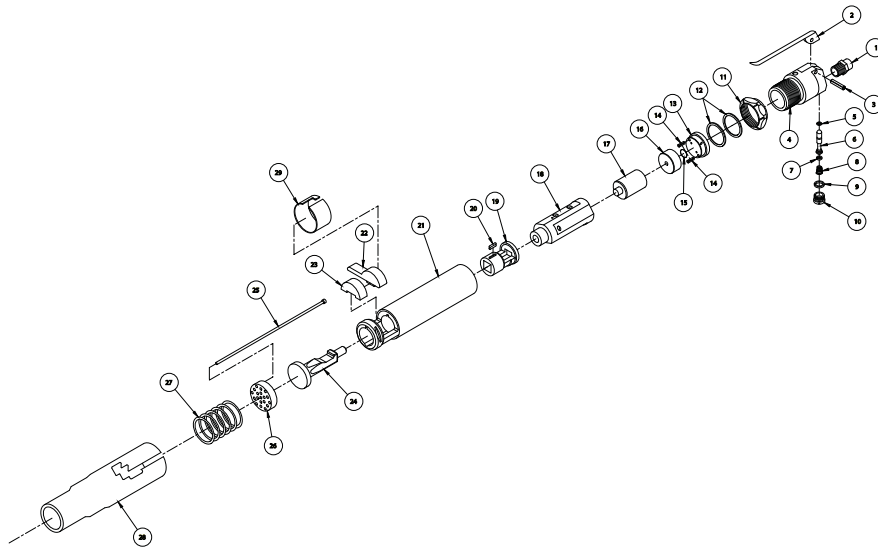

REGISTER YOUR PRODUCT ONLINE NOW!
<http://ch-commercial.com/registration/>

REPLACEMENT PARTS LIST

Ref. No.	Description	Part No.	Qty.
1	1/4 inch - 18 NPT Inlet	—	1
2	Lever	—	1
3	Roll pin	—	1
4	Backhead	—	1
5	O-ring	●	1
6	Throttle valve	—	1
7	O-ring	●	1
8	Spring	●	1
9	Gasket	●	1
10	Valve cap	—	1
11	Lock ring	—	1
12	Alignment shim	—	2
13	Rear valve block	—	1
14	Roll pins	—	2
15	Valve	—	1
16	Front valve block	—	1
17	Piston	—	1
18	Barrel sleeve	—	1
19	Nose	—	1
20	Key	—	1
21	Barrel assembly	—	1
22	Driver retainer	—	1
23	Retainer buffer	—	1
24	Needle driver	▲	1
25	Needle	■	19
26	Inlet bushing	▲	1
27	Spring	▲	1
28	Needle Tube	—	1
29	Retainer clip	—	1

REPLACEMENT PARTS KITS

▲	Driver assembly kit	SV158102AV
■	Needle set	SV158212AV
●	Rebuild kit	SV158103AV
—	Not available	

Marteau à aiguilles



MODÈLE : CL158101AV

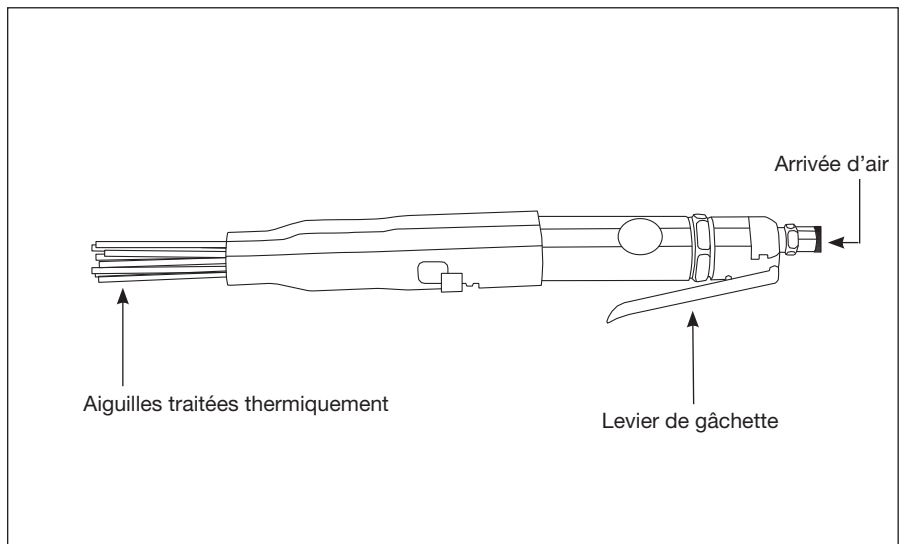

Description

Les marteaux à aiguilles en ligne sont conçus pour retirer l'accumulation de flux des soudures.

Spécifications

Valeur nominale de coups par minutes	4,000
Consommation d'air243.5 l/min. @ 621 kPa moyenne (usage 45%)	
Consommation d'air543.7 l/min. @ 621 kPa continue (usage 100%)	
Pression de Service Maximum.	621 kPa
Arrivée d'air.	3/8 po NPT (Femelle)
Taille de tuyau minimum	3/8 po
Longueur de coup	1/4 po (6,4mm)
Quantité d'aiguilles	19
Dimension de l'aiguille	1/8 po
Poids.	2.72 kg

Pour pièces de rechange ou assistance technique, appeler 1-855-504-5678

S'il vous plaît fournir l'information suivante :

- Numéro de Modèle
- Numéro de série (si présent)
- Description et numéro de la pièce

Adresser toute correspondance à :

Campbell Hausfeld
Attn: Customer Service
100 Production Drive
Harrison, OH 45030 U.S.A.

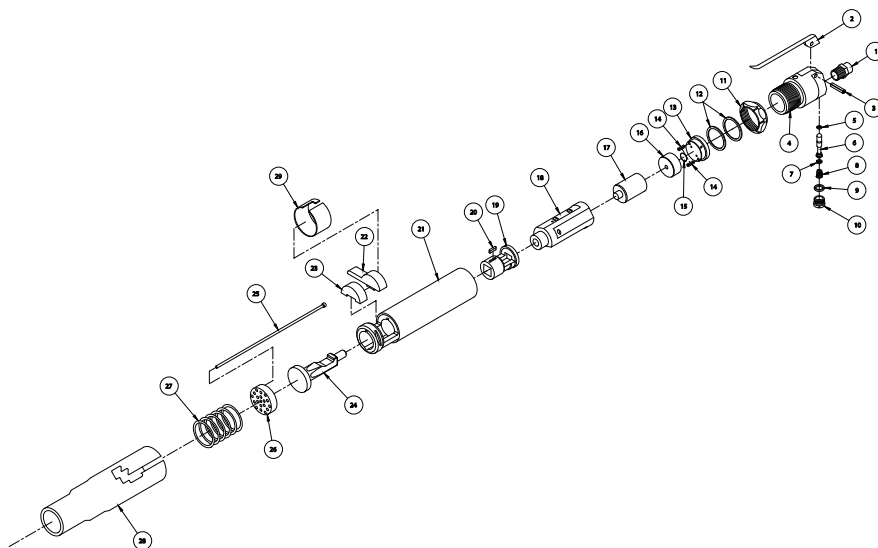

ENREGISTREZ VOTRE PRODUIT EN LIGNE MAINTENANT !
<http://ch-commercial.com/registration/>

LISTE DE PIÈCES DE RECHANGE

N° de réf.	Description	N° de pièce	Qté.
1	6,4 mm (1/4 po) - 18 NPT Entrée	—	1
2	Levier	—	1
3	Goupille-ressort	—	1
4	Tête arrière	—	1
5	Joint torique	●	1
6	Soupape d'accélérateur	—	1
7	Joint torique	●	1
8	Ressort	●	1
9	Joint d'étanchéité	●	1
10	Capuchon de soupape	—	1
11	Bague d'arrêt	—	1
12	Cale d'alignement	—	2
13	Bloc de soupape arrière	—	1
14	Goupille-ressorts	—	2
15	Soupape	—	1
16	Bloc de soupape avant	—	1
17	Piston	—	1
18	Manchon de tube	—	1
19	Nez	—	1
20	Clé	—	1
21	Assemblage de tube	—	1
22	Dispositif de retenue d'entraînement	—	1
23	Amortisseur de retenue	—	1
24	Entraînement d'aiguille	▲	1
25	Aiguille	■	19
26	Porte-aiguille	▲	1
27	Ressort	▲	1
28	Tube d'aiguille	—	1
29	Pince de retenue	—	1

NÉCESSAIRES DE PIÈCES DE RECHANGE

▲	Trousse d'assemblage d'entraînement	SV158102AV
■	Jeu d'aiguilles	SV158212AV
●	Nécessaires de remise en état	SV158103AV
—	Pas disponible	

Manual de Peças de Substituição
Desincrustador de agulha



MODELO: CL158101AV

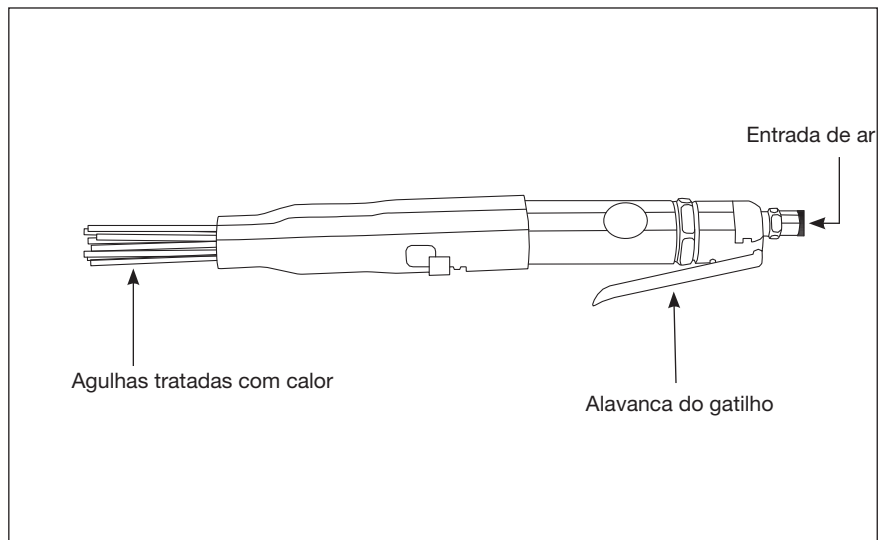

Descrição

Os desincrustadores de agulha em linha são desenhados para remover o fluxo formado das soldas.

Especificações

Golpes por minuto: 4,000
Consumo médio de ar . . 243.5 l/min. @ 6,21 bar
(45% de uso)
Consumo de ar cont. . . . 543.7 l/min. @ 6,21 bar
(100% de uso)
Pressão máxima de operação 6,21 bar
Entrada de ar 6,4 mm (1/4 pol.) NPT (Fêmea)
Orifício mínimo de mangueira . 9,5 mm (3/8 pol.)
Comprimento do curso: 6,4 mm (1/4 pol.)
Quantidade de agulhas: 19
Dimensão de agulha: 3,2 mm (1/8 pol.)
Peso: 2.72 kg

**Para peças de reposição ou assistência técnica,
entre em contato com o seu distribuidor local**

Por favor forneça as seguintes informações:

- Número do modelo
- Número de série (se houver)
- Descrição e número da peça como mostrado na lista de peças

Envie as correspondências para:

Campbell Hausfeld
Attn: Customer Service
100 Production Drive
Harrison, OH 45030 U.S.A.

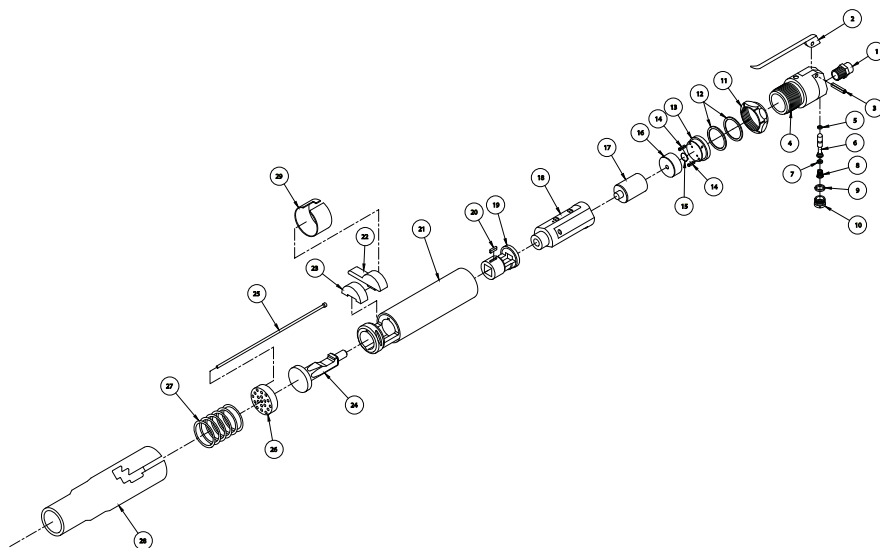

REGISTRE SEU PRODUTO ON-LINE AGORA!
<http://ch-commercial.com/registration/>

LISTA DE PEÇAS DE REPOSIÇÃO

No. de Ref.	Descrição	Número da Peça	Qtd.
1	Entrada de 6,4 mm (1/4 pol.) - 18 NPT	—	1
2	Alavanca	—	1
3	Pino de rotação	—	1
4	Cabeça traseira	—	1
5	Anel em "O"	●	1
6	Válvula do regulador	—	1
7	Anel em "O"	●	1
8	Mola	●	1
9	Gaxeta	●	1
10	Tampo da válvula	—	1
11	Anel de segurança	—	1
12	Calço de alinhamento	—	2
13	Bloqueio de válvula posterior	—	1
14	Pino de rotação	—	2
15	Válvula	—	1
16	Bloqueio de válvula frontal	—	1
17	Pistão	—	1
18	Manga do barril	—	1
19	Ponta	—	1
20	Chave	—	1
21	Montagem do barril	—	1
22	Retentor do motor	—	1
23	Amortecedor do retentor	—	1
24	Motor da agulha	▲	1
25	Agulha	■	19
26	Suporte da agulha	▲	1
27	Mola	▲	1
28	Tubo da agulha	—	1
29	Clipe do retentor	—	1

CONJUNTOS DE PECAS DE REPOSICÃO

▲	Kit de montagem do motor	SV158102AV
■	Conjunto de agulhas	SV158212AV
●	Jugo de remontagem	SV158103AV
—	Não disponível	

Decapadora

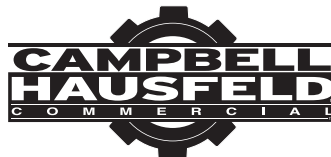

MODELO: CL158101AV

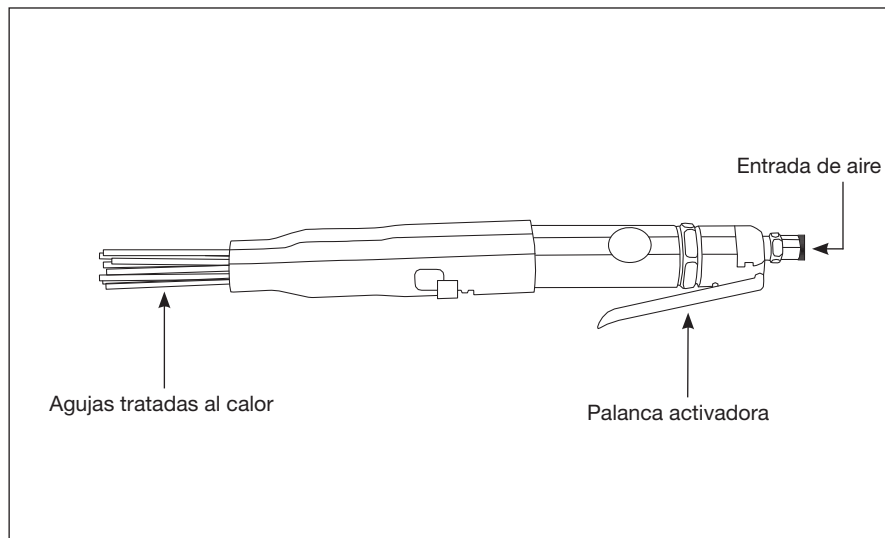

Descripción

Las decapadoras en línea están diseñadas para eliminar acumulación de fundente de las soldaduras.

Especificaciones

Impactos por minuto	4,000
Prom. de consumo de aire (45% de uso)	243.5 l/min. @ 6,21 bar
Consumo continuo de aire (100% de uso)	543.7 l/min. @ 6,21 bar
Máx. presión operativa	6,21 bar
Entrada de aire	6,4 mm (1/4 pulg.) NPT (H)
Diámetro mínimo de la manguera	9,5 mm (3/8 pulg.)
Longitud del desplazamiento	6,4 mm (1/4 pulg.)
Cantidad de agujas	19
Tamaño de la aguja	3,2 mm (1/8 pulg.)
Peso	2.72 kg

**Para Ordenar Repuestos o Asistencia Técnica,
Sírvese Llamar al Distribuidor Más Cercano a Su
Domicilio**

Sírvase darnos la siguiente información:

- Número del modelo
- Código impreso (si correspondiera)
- Descripción y número del repuesto según la lista de repuestos

Dirija toda la correspondencia a:

Campbell Hausfeld
Attn: Customer Service
100 Production Drive
Harrison, OH 45030 U.S.A.

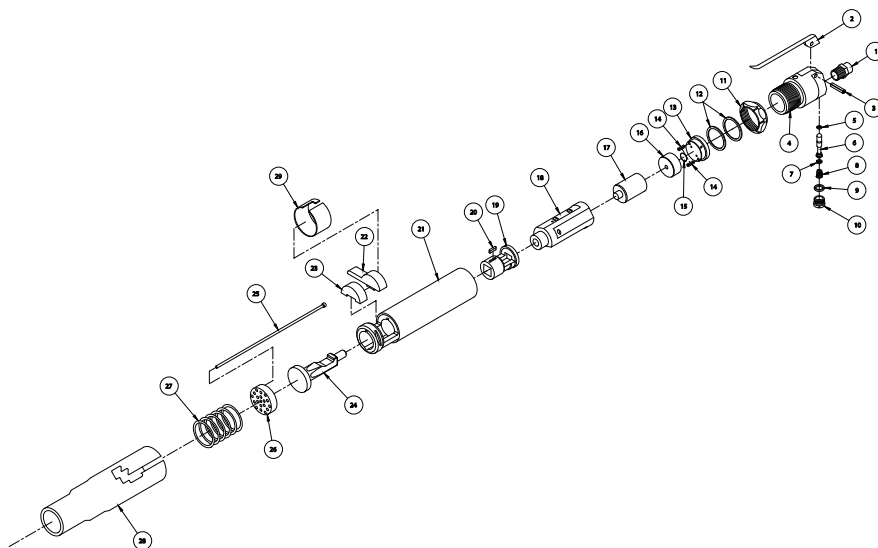

¡REGISTRE SU PRODUCTO EN LÍNEA AHORA MISMO!
<http://ch-commercial.com/registration/>

LISTA DE PARTES DE REPARACIÓN

No. de Ref.	Descripción	No. de Parte	Ctd.
1	6,4 mm (1/4 pulg.) - 18 PTN de entrada	—	1
2	Palanca	—	1
3	Pasador	—	1
4	Cabeza trasera	—	1
5	Anillo en O	●	1
6	Válvula de regulación	—	1
7	Anillo en O	●	1
8	Resorte	●	1
9	Empaque	●	1
10	Tapa de la válvula	—	1
11	Anillo de seguridad	—	1
12	Cuña de alineación	—	2
13	Bloqueo de válvula trasera	—	1
14	Pasadores	—	2
15	Válvula	—	1
16	Bloqueo de válvula delantera	—	1
17	Pistón	—	1
18	Camisa del tambor	—	1
19	Punta	—	1
20	llave	—	1
21	Ensamblaje del tambor	—	1
22	Retén del impulsor	—	1
23	Amortiguador del retén	—	1
24	Impulsor de la aguja	▲	1
25	Aguja	■	19
26	Soporte de la aguja	▲	1
27	Resorte	▲	1
28	Tubo de la aguja	—	1
29	Broche del retén	—	1

JUEGOS DE REPUESTOS DISPONIBLES

▲	Juego de ensamblaje del impulsor	SV158102AV
■	Juego de agujas	SV158212AV
●	Para el acondicionamiento	SV158103AV
—	No disponible	

Notas
