



**THE RIGHT FITTING FOR
THE RIGHT JOB. INNOVATION.
PERFORMANCE. DURABILITY.
BUILT ON TRUST.
BUILT ON QUALITY.
SUPERIOR CUSTOMER SERVICE.
IT'S WHAT MAKES US FLOW.**





WHEN QUALITY'S ON THE LINE, RELY ON CAMPBELL HAUSFELD.

Campbell Hausfeld is a global provider of quality flow products for the residential, commercial and industrial markets. Delivering quality flow products and superior customer service for decades.

Campbell Hausfeld, a Marmon/Berkshire Hathaway company, has been helping people get jobs done for more than 180 years. We started in 1836 by creating agricultural equipment to help make farmers' work easier. Since 1940, we've produced air compressors to help build a growing America.

Today, Campbell Hausfeld is embarking on a new journey. We have expanded into additional product lines that fit with the markets we serve. Reflecting this change, Campbell Hausfeld now hosts a variety of product options including brass fittings and valves.

Our expertise as a manufacturer has enabled us to grow into a full-service flow company. In this role, Campbell Hausfeld is proud to offer the strength and reliability of a trusted name as we begin our expansion into the plumbing product solutions.

To help you stay ahead of the competition, we look forward to providing you with the highest-quality, competitively priced products and value-added services now and in the future.

To learn more about our entire range of products, visit campbellhausfeld.com or call us at (800) 241-7335. We look forward to serving you.



Table of Contents

REFERENCE DATA

Brass Alloys.....	4
Numbering System.....	5
Brass Fittings Selection & Application Guide.....	6
How to install tubing.....	7
Manufacturing Techniques.....	8
Decimal and Metric Equivalents of Fractions.....	9
Visual Index.....	10

FITTINGS & VALVES

SAE 45° Flare.....	15
Inverted Flare.....	26
Brass Pipe.....	29
Red Brass Pipe.....	41
Compression.....	45
A-Lign Compression.....	53
D.O.T. Nylon Tube Air Brake.....	55
Garden Hose.....	59
Hose Barb.....	64
Grip-On Hose Barb.....	68
POL.....	72
Needle Valves.....	74
Special Duty Valves.....	77
Ground Plug Valves.....	80
Hose & Truck Valves.....	83
Drain Cocks.....	85

ASSORTMENT KITS & TOOLS

Assortment Kits.....	89
Tools.....	93

APPENDIX

Alpha-Numeric Appendix.....	94
Terms & Conditions.....	96
Credit Application.....	99



Brass Alloys

Campbell Hausfeld takes great pride in making certain our customers use the right brass alloy for their application. After all, while CA360 brass is an excellent material for many purposes, it isn't necessarily the best way to go for all scenarios.

To understand the advantages of different brass alloys, it is important to review the fundamental chemistry of brass. Each alloy is comprised of three main elements. In order of material content, these elements are Copper, Zinc and Lead. Different combinations of these elements affect the chemical resistance, thermal properties, machineability characteristics and applicability for potable water and other regulated applications.

The following table outlines the composition of several brass alloys Campbell Hausfeld machines for different applications.

	C2680 Yellow Brass	C36000 Yellow Brass	C37700 Yellow Brass	C23000 Red Brass	C31400 Red Brass	AB1953 #59-0 Brass
Copper Min/Max	64.00% 68.00%	60.00% 63.00%	58.00% 62.00%	84.00% 86.00%	87.50% 90.50%	58.00% 59.00%
Zinc Min/Max	Remainder	32.95% 37.50%	34.70% 40.80%	14.00% 16.00%	6.20% 11.20%	41.80% 39.75%
Lead Min/Max	00.00% 00.05%	2.50% 3.70%	1.20% 2.50%	0.00% 0.05%	1.30% 2.50%	00.20% 00.25%
Other Min/Max	00.00% 00.05%	0.00% 0.35%	00.00% 00.80%	0.00% 0.05%	0.00% 0.80%	00.00% 1.00%

To understand the importance of the different compositions, consider an example from the front page of most newspapers across the USA. Lead content in consumer products is facing increasing scrutiny by the media and government regulatory agencies. This is especially true where the product comes into direct contact with drinking water. Several states have either already regulated or will soon regulate the acceptable lead content in brass components for plumbing applications. Campbell Hausfeld's Lead Free #59-0 brass is the best solution available in the market today for addressing lead concerns in brass fittings.



Numbering Systems

Each part number indicates the style and size of the fitting. The letters and/or numbers preceding the dash indicate the style and the letters and/or numbers following the dash indicate the size.

For example, E1-4A is an elbow, flare to male pipe thread. The size is 1/4" OD tube by 1/8" male pipe thread.

ALL TUBING SIZES USED IN THIS CATALOG ARE O.D. TUBE SIZE UNLESS OTHERWISE INDICATED.

The numbers and/or letters following the dash show the sizes of the fitting in accordance with the following specifications:

O.D. Tube Size	1/8"	3/16"	1/4"	5/16"	3/8"	7/16"	1/2"	5/8"	3/4"	7/8"	1"
Part No.	-2	-3	-4	-5	-6	-7	-8	-10	-12	-14	-16

	STYLE IS GENERALLY IDENTIFIED BY LAST DIGIT	INVERTED FLARE	COMPRESSION	NAB NYLON AIR BRAKE	FLARE
SLEEVES	0	X	60A-	60NAB-	X
NUTS	1	41I-	61A-	61NAB-	N1/ ⁴¹ Series
UNIONS	2	42I-	62A-	62NAB-	U2/ ⁴² Series
UNION TEES	4	44I-	64A-	64NAB-	T2/ ⁴⁴ Series
FEMALE CONNECTORS	6	46I-	66A-	66NAB-	U3/ ⁴⁶ Series
MALE CONNECTORS	8	48I-	68A-	VS68NAB-	U1/ ⁴⁸ Series
MALE ELBOWS	9	49I-	69A-	VS69NAB-	E1/ ⁴⁹ Series



Brass Fittings Selection & Application Guide

		DOUBLE COMPRESSION	PIPE	INVERTED FLARE	SAE 45 FLARE	COMPRESSION	A-LIGN	COPPER AIR BRAKE	NYLON AIR BRAKE
		BRASS	BRASS	BRASS	BRASS	BRASS	BRASS	BRASS	BRASS
TUBE SIZE (O.D. RANGE IN INCHES)	1/8	1/8	1/8	1/8	1/8	1/8	1/8	1/4	1/4
	3/8	1	5/8	1	7/8	3/4	3/4	3/4	3/4
MAXIMUM WORKING PRESSURE (PSI) DEPENDS ON TUBING MATERIAL, O.D. WALL THICKNESS AND FITTING	500	1200	2000	2000	400	800	150	150	
VIBRATION CHARACTERISTICS	FAIR	*	*			*		*	
	GOOD				*		*		
	EXCELLENT			*					*
TUBING	COPPER	*		*	*	*	*	*	
	STEEL			*	*				
	ALUMINUM	*		*	*	*	*		
	POLYETHYLENE					*	*		
	NYLON					*	*	*	*
	POLYVINYL CHLORIDE (PVC)					*	*		
	BUNDY			*	*	2*	2*		
CONFORMANCE	SAE		*	*	*	*		*	*
	ASA	*	*	*	*	*			
	ASME	*	*	*	*	*			
	DOT							*	*
APPLICATION	INSTRUMENTATION		*	*	*	*	*	*	*
	OIL-AIR-WATER	*	*	*	*	*	*	*	*
	REFRIGERATION				*				
	HYDRAULIC SYSTEMS		*	*	*	*			
	COOLING SYSTEMS	*	*	*	*	*	*	*	*
	LUBRICATION SYSTEMS	*	*	*	*	*	*	*	*
	AIR BRAKE								*
1 - BRASS SLEEVE <input type="checkbox"/> - RECOMMENDED APPLICATION 2 - TIN DIPPED									

Published literature at the time of initial publication reflects all current design, dimensions and performance data. However, in keeping with our policy of upgrading products on an on-going basis, modifications may result in changes in design, dimensions and/or performance currently shown in this catalog. Working pressures and other technical information has been prepared from sources deemed to be reliable but no responsibility can be assumed by Cerro Industrial for the accuracy of this information under various field conditions. It should be considered as a recommendation only and not a guarantee.

How to Install Tubing

PRECAUTIONS

1. Avoid straight line connections wherever possible, especially in short runs.
2. Design piping systems symmetrically. They are easier to install and present a neat appearance.
3. Care should be taken to eliminate stress from tubing lines. Long tubing runs should be supported by brackets or clips. All parts installed on tubing lines such as heavy fittings, valves, etc., should be bolted down to eliminate tubing fatigue.
4. Before installing tubing, inspect the tube to see that it conforms to the required specifications, is of the correct diameter and wall thickness and is not out of round.
5. Cut tube ends reasonably square and lightly deburr inside and outside edge. Chamfer on outside edge will destroy bearing of tube end on the fitting seat.
6. To avoid difficulty in assembly and disconnecting, a sufficient straight length of tube must be allowed from the end of the tube to the start of the bend.
7. Allow twice the length of the nut as a minimum.
8. Tubes should be formed to assemble with true alignment to the center line of the fittings, without distortion or tension.

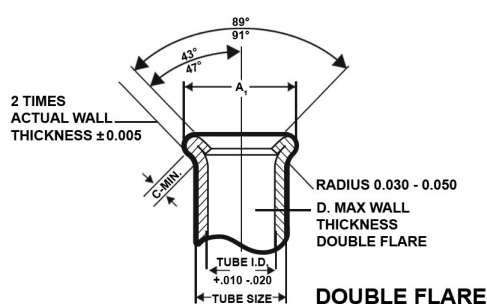
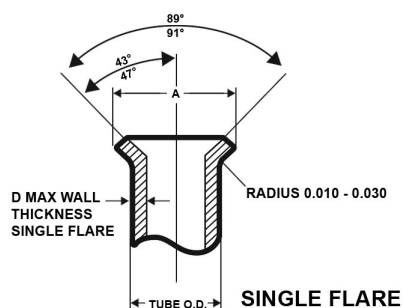
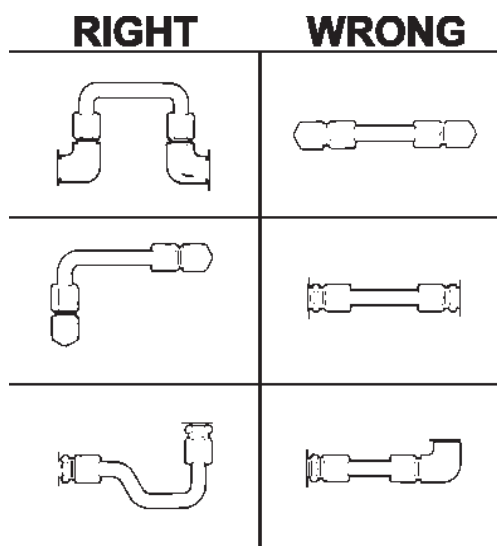

Nominal Tube OD	A Single Flare Diameter		A ₁ Double Flare Diameter		B Single Flare Radius		B ₁ Double Flare Radius		C Double Flare Coined Seat Length		D _b Single Flare Coined Seat Length		D _{1b} Double Flare Wall Thickness						
	in	mm	in	mm	in	mm	in	mm	in	mm	in	mm	in	mm					
1/8	3.18	0.181	0.171	4.59	4.35	0.213	0.198	5.41	5.03	0.02	0.51	0.04	1.02	0.040	1.02	0.035	0.88	0.025	0.63
3/16	4.76	0.249	0.239	6.32	6.08	0.280	0.265	7.11	6.74	0.02	0.51	0.04	1.02	0.040	1.02	0.035	0.88	0.028	0.71
1/4	6.35	0.325	0.315	8.25	8.01	0.360	0.345	9.14	8.77	0.02	0.51	0.04	1.02	0.040	1.02	0.049	1.24	0.035	0.83
5/16	7.94	0.404	0.388	10.26	9.86	0.425	0.410	10.79	10.42	0.02	0.51	0.04	1.02	0.062	1.57	0.049	1.24	0.035	0.88
3/8	9.52	0.487	0.471	12.36	11.97	0.500	0.485	12.70	12.32	0.02	0.51	0.04	1.02	0.062	1.57	0.065	1.65	0.049	1.24
7/16	11.11	0.561	0.545	14.24	13.85	0.570	0.555	14.47	14.10	0.02	0.51	0.04	1.02	0.062	1.57	0.065	1.65	0.049	1.24
1/2	12.70	0.623	0.607	15.82	15.42	0.640	0.625	16.25	15.88	0.02	0.51	0.04	1.02	0.062	1.57	0.083	2.10	0.049	1.24
9/16	14.29	0.676	0.660	17.17	16.77	0.712	0.697	18.08	17.71	0.02	0.51	0.04	1.02	0.062	1.57	0.083	2.10	0.049	1.24
5/8	15.88	0.748	0.732	18.99	18.60	0.772	0.757	19.60	19.23	0.02	0.51	0.04	1.02	0.062	1.57	0.095	2.41	0.049	1.24
3/4	19.05	0.916	0.900	23.26	22.86	0.912	0.897	23.16	22.79	0.02	0.51	0.04	1.02	0.062	1.57	0.109	2.76	0.049	1.24
7/8	22.22	1.041	1.025	26.44	26.04	-	-	-	-	0.02	0.51	-	-	-	-	0.109	2.76	-	-
1	25.40	1.157	1.141	29.38	28.99	-	-	-	-	0.02	0.51	-	-	-	-	0.120	3.04	-	-



Manufacturing Techniques



Forged Fittings

Brass for forged fittings is extruded into round bars, cut to length and then straightened. After straightening, the bars are cut into short lengths (slugs), reheated to the pliable state and pressed between upper and lower die cavities at a pressure in excess of 25,000 pounds per square inch. After cooling, the excess material is trimmed away and the forged blank is ready for machining. This process produces a uniform piece of brass with exceptional strength. Because the grain flow follows the contour of the blank, the finished fitting has high impact strength and is resistant to mechanical shock and vibration.

Extruded Fittings

Special shaped bars, as well as hexagon and round bars, are extruded to the required shape, then drawn to size, cut to length and straightened. To do this, the solid, round billet, varying from 8 to 12 inches in diameter, is heated and then forced by a pressure of approximately 80,000 pounds per square inch through a die of the desired shape. The resulting bar is cooled and then drawn again through additional dies to the desired shape. After straightening, the bar is ready for machining. The process produces a dense, non-porous material.

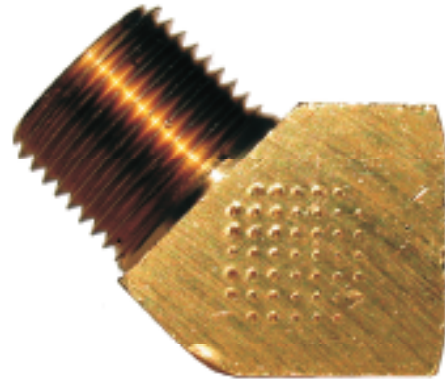

Campbell Hausfeld Dry Seal Pipe Thread

Dryseal Pipe Threads

Pipe threads are made to the Dryseal USA (American) Standard Taper Pipe Thread standard, known as NPTF, which seals joints pressure tight.

The dryseal pipe thread roots are wider than the crests. When the threads are wrenched together, the roots crush the sharper crests of the mating threads. This forms a metal to metal seat. Dryseal threads improve the seating characteristics, especially when a thread sealant is used.

Dryseal pipe threads hand-tight.	Dryseal pipe threads wrench-tight. Seals tightly on all sides for positive sealing action.	Regular pipe threads hand-tight. Seals joints on the sides only and does not prevent spiral leakage.











































Decimal and Metric Equivalents of Fractions

FRACTION	DECIMAL	METRIC (mm)	FRACTION	DECIMAL	METRIC (mm)
1/64	0.0156	0.397	33/64	0.5156	13.097
1/32	0.0313	0.794	17/32	0.5313	13.494
3/64	0.0469	1.191	35/64	0.5469	13.891
1/16	0.0625	1.588	9/16	0.5625	14.288
5/64	0.0781	1.984	37/64	0.5781	14.684
3/32	0.0938	2.381	19/32	0.5938	15.081
7/64	0.1094	2.778	39/64	0.6094	15.478
1/8	0.1250	3.175	5/8	0.6250	15.875
9/64	0.1406	3.572	41/64	0.6406	16.272
5/32	0.1562	3.969	21/32	0.6562	16.669
11/64	0.1719	4.366	43/64	0.6719	17.066
3/16	0.1875	4.762	11/16	0.6875	17.462
13/64	0.2031	5.159	45/64	0.7031	17.859
7/32	0.2188	5.556	23/32	0.7188	18.256
15/64	0.2344	5.953	47/64	0.7344	18.653
1/4	0.2500	6.350	3/4	0.7500	19.050
17/64	0.2656	6.747	49/64	0.7656	19.447
9/32	0.2812	7.144	25/32	0.7812	19.844
19/64	0.2969	7.541	51/64	0.7969	20.241
5/16	0.3125	7.938	13/16	0.8125	20.638
21/64	0.3281	8.334	53/64	0.8281	21.034
11/32	0.3438	8.731	27/32	0.8438	21.431
23/64	0.3594	9.128	55/64	0.8594	21.828
3/8	0.3750	9.525	7/8	0.8750	22.225
25/64	0.3906	9.922	57/64	0.8906	22.822
13/32	0.4062	10.319	29/32	0.9062	23.019
27/64	0.4219	10.716	59/64	0.9219	23.416
7/16	0.4375	11.112	15/16	0.9375	23.812
29/64	0.4531	11.509	61/64	0.9531	24.209
15/32	0.4688	11.906	31/32	0.9688	24.606
31/64	0.4844	12.303	63/64	0.9844	25.003
1/2	0.5000	12.700	1	1.0000	25.400



Visual Index

SAE 45° Flare	P-B1  Pg. 16	P-B2  Pg. 16	P-C1  Pg. 16	P-DE3  Pg. 16	P-E1  Pg. 17	P-E1-45  Pg. 17	
	P-E2  Pg. 18	P-E3  Pg. 18	P-E4  Pg. 18	P-N1  Pg. 19	P-N2  Pg. 19	P-N4  Pg. 19	P-N5  Pg. 19
	P-NS4  Pg. 20	P-NSR4  Pg. 20	P-P2  Pg. 20	P-T1  Pg. 21	P-T2  Pg. 21	P-T3  Pg. 21	P-TR2  Pg. 22
	P-U1  Pg. 22	P-U2  Pg. 23	P-U3  Pg. 23	P-UR2  Pg. 23	P-UR3  Pg. 24	P-US4  Pg. 24	P-N1CT  Pg. 24
	P-U1CT  Pg. 24	P-U2CT  Pg. 24	P-U3CT  Pg. 25	P-E3GA  Pg. 25	P-N5GA  Pg. 25	P-U1GA  Pg. 25	P-U3GA  Pg. 25
	Inverted Flare	P-411B  Pg. 27	P-411S  Pg. 27	P-421  Pg. 27	P-461  Pg. 27	P-481  Pg. 28	P-491  Pg. 28

Visual Index

Brass Pipe	P-100A  Pg. 30	P-100X  Pg. 30	P-100A-45  Pg. 30	P-100X-45  Pg. 30	P-101A  Pg. 30	P-101X  Pg. 31		
	P-102A  Pg. 31	P-102X  Pg. 31	P-103A  Pg. 31	P-103AH  Pg. 31	P-104A  Pg. 32	P-108A  Pg. 32	P-109A  Pg. 32	
	P-109AS  Pg. 32	P-109CS  Pg. 32	P-110A  Pg. 33	P-110AH  Pg. 33	P-110FB  Pg. 33	P-111A  Pg. 34	P-112A  Pg. 34	
	P-113A  Pg. 34	P-113RB  Pg. 35	P-116A  Pg. 35	P-116AL  Pg. 36	P-116AM  Pg. 36	P-116X  Pg. 36	P-117A  Pg. 36	
	P-119A  Pg. 36	P-119AH  Pg. 37	P-120A  Pg. 37	P-120AH  Pg. 37	P-121A  Pg. 37	P-121AS  Pg. 38	P-122A  Pg. 38	
	P-122AH  Pg. 38	P-123A  Pg. 38	P-123AH  Pg. 39	P-124Δ  Pg. 39	P-124X  Pg. 39	P-127A  Pg. 39	P-127X  Pg. 40	
	P-128A  Pg. 40	P-129A  Pg. 40	P-T9  Pg. 40					
	Red Brass Pipe	P-100RB  Pg. 41	P-100-45RB  Pg. 41	P-101RB  Pg. 41	P-103RB  Pg. 31	P-104RB  Pg. 42	P-108RB  Pg. 42	
		P-109RB  Pg. 42	P-110FRB  Pg. 42	P-110RB  Pg. 42	P-112RB  Pg. 43	P-116RB  Pg. 43	P-119RB  Pg. 43	P-124RB  Pg. 43
		P-125RB  Pg. 43	P-113RB  Pg. 44					



Visual Index











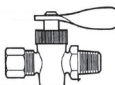
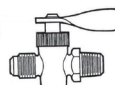
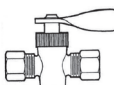
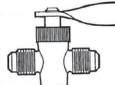

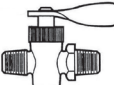









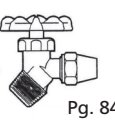
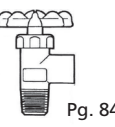
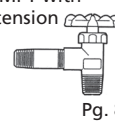

Compression	P-60A  Pg. 46	P-60AE  Pg. 46	P-60AP  Pg. 46	P-61A  Pg.46	P-161A  Pg. 47	P-62A  Pg. 47	
	P-64A  Pg. 47	P-65A  Pg. 48	P-66A  Pg. 49	P-68A  Pg. 49	P-6945A  Pg. 49	P-69A  Pg. 50	P-70A  Pg. 50
	P-71A  Pg. 51	P-72A  Pg. 51	P-76A  Pg. 51	P-81LB  Pg. 52	P-N5CT  Pg. 52		
A-Lign Compression	P-961A  Pg. 54						
	DOT Nylon Air Brake	P-59A  Pg. 56	P-60NAB  Pg. 56	P-61NAB  Pg. 56	P-62NAB  Pg. 56	P-64NAB  Pg. 56	P-65NAB  Pg. 57
	P-66NAB  Pg. 57	P-VS68NAB  Pg. 57	P-VS69NAB  Pg. 57	P-70NAB  Pg. 58	P-VS71NAB  Pg. 58	P-VS72NAB  Pg. 58	P-VS79NAB  Pg. 58
Garden Hose	P-5A  Pg. 60	P-5AS  Pg. 60	P-18A  Pg. 60	P-19A  Pg. 60	P-20A  Pg. 60	P-21A  Pg. 60	
	P-22A  Pg. 61	P-22AS  Pg. 61	P-23A  Pg. 61	P-120EC  Pg. 61	P-201GH  Pg. 61	P-202GHS  Pg. 62	P-209GHS  Pg. 62
	P-ECD-D  Pg. 62	P-GH-W  Pg. 62	P-GHN1  Pg. 63	P-GHN5  Pg. 63	P-W1  Pg. 63	P-W1  Pg. 63	

Visual Index

Hose Barb	P-201A  Pg. 65	P-201BF  Pg. 65	P-209A  Pg. 66	P-209AS  Pg. 66	P-209ASF  Pg. 66	P-HBT2  Pg. 66
P-HE1  Pg. 67	P-HE1-45  Pg. 67	P-HM  Pg. 67				
Grip-On	P-301  Pg. 69	P-302  Pg. 69	P-303  Pg. 69	P-304  Pg. 69	P-305  Pg. 70	P-306  Pg. 70
P-307  Pg. 70	P-308  Pg. 70	P-309  Pg. 71	P-3099  Pg. 71	P-310  Pg. 71		
POL	P-POL-LN  Pg. 73	P-POL-N  Pg. 73	P-POL-LTPH  Pg. 73	P-POL-N5  Pg. 73	P-POL-P2  Pg. 73	P-POL-U2  Pg. 73
P-POL-U3  Pg. 73						
Needle Valves	FPT to FPT  Pg. 75	FPT to MPT  Pg. 75	Comp to MPT  Pg. 75	Comp to MPT, Angle  Pg. 75	Flare to MPT, Angle  Pg. 75	Flare to MPT  Pg. 75
Flare to Flare  Pg. 76	MPT to MPT  Pg. 76	Comp to Comp  Pg. 76	Self Tapping Valve  Pg. 76	Saddle Valve  Pg. 76		



Visual Index

Special Duty Valves	Comp to MPT  Pg. 78	Flare to MPT  Pg. 78	Comp to Comp  Pg. 86	Flare to Flare  Pg. 78	FPT to FPT  Pg. 78	MPT to MPT  Pg. 79
	FPT to MPT  Pg. 79	Four Way Valve  Pg. 79	Three Way Valve  Pg. 79			
Ground Plug Valves	Comp to MPT  Pg. 81	Flare to MPT  Pg. 81	Comp to Comp  Pg. 81	Flare to Flare  Pg. 81	MPT to MPT  Pg. 81	FPT to FPT  Pg. 82
	FPT to MPT  Pg. 82	Flare to MPT  Pg. 82	Lever Handle  Pg. 82	T Handle Drain Valve  Pg. 82		
Hose & Truck Valves	Hose Valve to MPT  Pg. 84	Oil Tank Flare to MPT  Pg. 84	Oil Tank MPT to FPT  Pg. 84	Oil Tank MPT to MPT with Extension  Pg. 84		
	Drain Cocks	MPT  Pg. 86	Hose Bibb  Pg. 86	Internal Seat  Pg. 86	External Seat  Pg. 86	Extension External Seat  Pg. 86
Air Cock  Pg. 87		Barrel Faucet  Pg. 87				

SAE 45° Flare

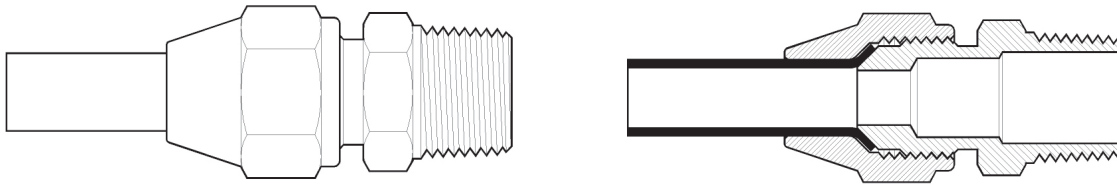

Tube O.D.	1/8	3/16	1/4	5/16	3/8	7/16	1/2	5/8	3/4	7/8
Thread	5/16-24	3/8-24	7/16-24	1/2-24	9/16-24	5/8-24	11/16-20	13/16-18	1-18	1 1/8-18

MATERIALS:

CA360, CA345, CA377

VIBRATION RESISTANCE:

Short Nut - Fair, Long Nut - Improved

WORKING PRESSURE:

2000 PSI Maximum based on tubing size
ALWAYS consult tubing specifications

TEMPERATURE RANGE:

-65 to +250°F
-54 to +121°C

CONFORMANCE:

Meets SAE, ASME and ASA Standards as noted by configuration.

APPLICATIONS:

LP Gas, refrigeration, natural gas, instrumentation, pneumatic systems, and other applications where copper, brass, aluminum and steel tubing are used.

TUBING MUST BE ABLE TO BE FLARED.

HOW TO ORDER:

- Order nuts and bodies separately.
- Some items available on Special Order basis only.

NOMENCLATURE:

P-E1-6B

- E1: Fitting Configuration
- 6: Tube Size in sixteenths (6/16 = 3/8)
- B: Pipe Size 1/4"
- Dimensions subject to change without notice

BENEFIT:

- Reduces maintenance costs and assembly time.
- Reduces the number of SKU's required to cover needs.
- More sales opportunities.

FEATURE:

- Reusable body and nut.
- Long nut vibration resistance.
- Extruded and Forged available.

ADVANTAGE:

- No need to replace when disassembling.
- Applicable in wider range of applications.
- Conforms to more customers' requirements.

ASSEMBLY INSTRUCTIONS:

- Cut tubing squarely and remove burrs.
- Slide nut on tubing, threaded end out.
- Flare tubing.
- Lubricate threads.
- Tighten nut onto body with wrench until snug plus 1/6 turn.

DO NOT OVER TIGHTEN OR TUBING MAY SPLIT



SAE 45° Flare



P-B1 BONNET COPPER

PART NUMBER	O.D. TUBE
P-B1-4	1/4 in
P-B1-6	3/8 in
P-B1-8	1/2 in
P-B1-10	5/8 in



P-B2 GASKET COPPER

PART NUMBER	O.D. TUBE
P-B2-4	1/4 in
P-B2-6	3/8 in
P-B2-8	1/2 in
P-B2-10	5/8 in



P-C1 CROSS, TUBE ALL ENDS

PART NUMBER	O.D. TUBE
P-C1-4444	1/4 in
P-C1-6666	3/8 in
P-C1-8888	1/2 in
P-C1-101010	5/8 in

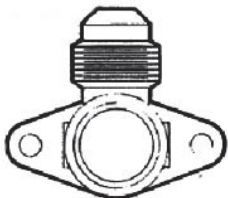

P-DE3 DROP EAR ELBOW, TUBE TO FPT

PART NUMBER	O.D. TUBE	PIPE THREAD SIZE
P-DE3-6D	3/8 in	1/2 in
P-DE3-8D	1/2 in	1/2 in
P-DE3-10D	5/8 in	1/2 in

SAE 45° Flare

P-E1 ELBOW 90° TUBE TO MPT 49 SERIES

PART NUMBER	O.D. TUBE	PIPE THREAD SIZE
P-E1-3A	3/16 in	1/8 in
P-E1-3B	3/16 in	1/4 in
P-E1-4A	1/4 in	1/8 in
P-E1-4B	1/4 in	1/4 in
P-E1-4C	1/4 in	3/8 in
P-E1-4D	1/4 in	1/2 in
P-E1-5A	5/16 in	1/8 in
P-E1-5B	5/16 in	1/4 in
P-E1-5C	5/16 in	3/8 in
P-E1-6A	3/8 in	1/8 in
P-E1-6B	3/8 in	1/4 in
P-E1-6C	3/8 in	3/8 in
P-E1-6D	3/8 in	1/2 in
P-E1-6E	3/8 in	3/4 in
P-E1-8B	1/2 in	1/4 in
P-E1-8C	1/2 in	3/8 in
P-E1-8D	1/2 in	1/2 in
P-E1-8E	1/2 in	3/4 in
P-E1-10B	5/8 in	1/4 in
P-E1-10C	5/8 in	3/8 in
P-E1-10D	5/8 in	1/2 in
P-E1-10E	5/8 in	3/4 in
P-E1-12C	3/4 in	3/8 in
P-E1-12D	3/4 in	1/2 in
P-E1-12E	3/4 in	3/4 in
P-E1-14E	7/8 in	3/4 in
P-E1-16E	1 in	3/4 in
P-E1-16F	1 in	1 in



FOR REFERENCE ONLY -
SAE 010202

P-E1-45 ELBOW 45° TUBE TO MPT 59 SERIES

PART NUMBER	O.D. TUBE	PIPE THREAD SIZE
P-E1-45-4A	1/4 in	1/8 in
P-E1-45-4B	1/4 in	1/4 in
P-E1-45-5A	5/16 in	1/8 in
P-E1-45-5B	5/16 in	1/4 in
P-E1-45-6B	3/8 in	1/4 in
P-E1-45-6C	3/8 in	3/8 in
P-E1-45-6D	3/8 in	1/2 in
P-E1-45-8C	1/2 in	3/8 in
P-E1-45-8D	1/2 in	1/2 in
P-E1-45-10C	5/8 in	3/8 in
P-E1-45-10D	5/8 in	1/2 in
P-E1-45-12D	3/4 in	1/2 in
P-E1-45-12E	3/4 in	3/4 in



FOR REFERENCE ONLY -
SAE 010302



SAE 45° Flare



FOR REFERENCE ONLY -
SAE 010201

P-E2 ELBOW, TUBE BOTH ENDS 55 SERIES

PART NUMBER	O.D. TUBE
P-E2-4	1/4 in
P-E2-5	5/16 in
P-E2-6	3/8 in
P-E2-8	1/2 in
P-E2-10	5/8 in



FOR REFERENCE ONLY -
SAE 010203

P-E3 ELBOW, TUBE TO FPT 50 SERIES

PART NUMBER	O.D. TUBE	PIPE THREAD SIZE
P-E3-4A	1/4 in	1/8 in
P-E3-4B	1/4 in	1/4 in
P-E3-4C	1/4 in	3/8 in
P-E3-5A	5/16 in	1/8 in
P-E3-5B	5/16 in	1/4 in
P-E3-6A	3/8 in	1/8 in
P-E3-6B	3/8 in	1/4 in
P-E3-6C	3/8 in	3/8 in
P-E3-6D	3/8 in	1/2 in
P-E3-6E	3/8 in	3/4 in
P-E3-8B	1/2 in	1/4 in
P-E3-8C	1/2 in	3/8 in
P-E3-8D	1/2 in	1/2 in
P-E3-8E	1/2 in	3/4 in
P-E3-10C	5/8 in	3/8 in
P-E3-10D	5/8 in	1/2 in
P-E3-10E	5/8 in	3/4 in

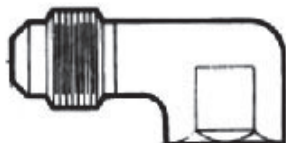

P-E4 ELBOW, TUBE TO FEMALE FLARE

PART NUMBER	O.D. TUBE
P-E4-44	1/4 in x 1/4 in
P-E4-66	3/8 in x 3/8 in

SAE 45° Flare

P-N1 MACHINED NUT, SHORT 55 SERIES

PART NUMBER	O.D. TUBE
P-N1-2	1/8 in
P-N1-3	3/16 in
P-N1-4	1/4 in
P-N1-5	5/16 in
P-N1-6	3/8 in
P-N1-8	1/2 in
P-N1-10	5/8 in
P-N1-12	3/4 in
P-N1-14	7/8 in

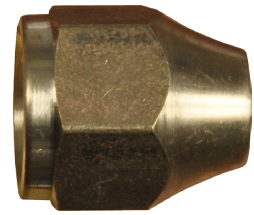

P-N2 MACHINED NUT, LONG

PART NUMBER	O.D. TUBE
P-N2-3	3/16 in
P-N2-4	1/4 in
P-N2-5	5/16 in
P-N2-6	3/8 in
P-N2-8	1/2 in
P-N2-10	5/8 in
P-N2-12	3/4 in



FOR REFERENCE ONLY -
SAE 010111

P-N4 FORGED NUT, LONG

PART NUMBER	O.D. TUBE
P-N4-4	1/4 in
P-N4-6	3/8 in
P-N4-8	1/2 in
P-N4-10	5/8 in
P-N4-12	3/4 in



FOR REFERENCE ONLY -
SAE 010167

P-N5 CAP, 40 SERIES

PART NUMBER	O.D. TUBE
P-N5-4	1/4 in
P-N5-5	5/16 in
P-N5-6	3/8 in
P-N5-8	1/2 in
P-N5-10	5/8 in
P-N5-12	3/4 in

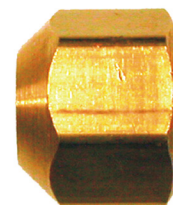

Use with P-B2-Copper Gasket



SAE 45° Flare



P-NS4 FORGED NUT, SHORT

PART NUMBER	O.D. TUBE
P-NS4-4	1/4 in
P-NS4-5	5/16 in
P-NS4-6	3/8 in
P-NS4-8	1/2 in
P-NS4-10	5/8 in
P-NS4-12	3/4 in
P-NS4-14	7/8 in



P-NSR4 FORGED NUT, SHORT REDUCING

PART NUMBER	O.D. TUBE
P-NSR4-64	3/8 in x 1/4 in
P-NSR4-65	3/8 in x 5/16 in
P-NSR4-86	1/2 in x 3/8 in
P-NSR4-106	5/8 in x 3/8 in
P-NSR4-108	5/8 in x 1/2 in

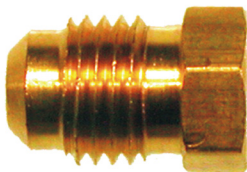

P-P2 PLUG, 39 SERIES

PART NUMBER	O.D. TUBE
P-P2-4	1/4 in
P-P2-5	5/16 in
P-P2-6	3/8 in
P-P2-8	1/2 in
P-P2-10	5/8 in
P-P2-12	3/4 in

SAE 45° Flare

P-T1 MALE BRANCH TEE, TUBE TO TUBE MPT 39 SERIES

PART NUMBER	O.D. TUBE	PIPE THREAD SIZE
P-T1-4A	1/4 in	1/8 in
P-T1-4B	1/4 in	1/4 in
P-T1-4C	1/4 in	3/8 in
P-T1-5A	5/16 in	1/8 in
P-T1-5B	5/16 in	1/4 in
P-T1-6A	3/8 in	1/8 in
P-T1-6B	3/8 in	1/4 in
P-T1-6C	3/8 in	3/8 in
P-T1-6D	3/8 in	1/2 in
P-T1-8C	1/2 in	3/8 in
P-T1-8D	1/2 in	1/2 in
P-T1-10C	5/8 in	3/8 in
P-T1-10D	5/8 in	1/2 in
P-T1-12D	3/4 in	1/2 in

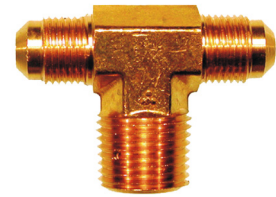

FOR REFERENCE ONLY -
SAE 010425

P-T2 TEE, TUBE ALL ENDS 44 SERIES

PART NUMBER	O.D. TUBE
P-T2-4	1/4 in
P-T2-5	5/16 in
P-T2-6	3/8 in
P-T2-8	1/2 in
P-T2-10	5/8 in
P-T2-12	3/4 in

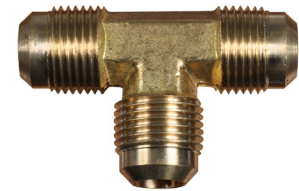

FOR REFERENCE ONLY -
SAE 010202

P-T3 MALE RUN TEE, TUBE TO MPT TO TUBE 39 SERIES

PART NUMBER	O.D. TUBE	PIPE THREAD SIZE
P-T3-3A	3/16 in	1/8 in
P-T3-4A	1/4 in	1/8 in
P-T3-4B	1/4 in	1/4 in
P-T3-4C	1/4 in	3/8 in
P-T3-5A	5/16 in	1/8 in
P-T3-5B	5/16 in	1/4 in
P-T3-6A	3/8 in	1/8 in
P-T3-6B	3/8 in	1/4 in
P-T3-6C	3/8 in	3/8 in
P-T3-6D	3/8 in	1/2 in
P-T3-8C	1/2 in	3/8 in
P-T3-8D	1/2 in	1/2 in

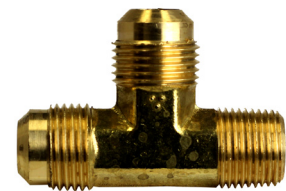

FOR REFERENCE ONLY -
SAE 010202



SAE 45° Flare



FOR REFERENCE ONLY -
SAE 010202

P-TR2 TEE, REDUCING FLARE ALL ENDS 44 SERIES

PART NUMBER	O.D. TUBE
P-TR2-446	1/4 in x 1/4 in x 3/8 in
P-TR2-464	1/4 in x 3/8 in x 1/4 in
P-TR2-466	1/4 in x 3/8 in x 3/8 in
P-TR2-664	3/8 in x 3/8 in x 1/4 in
P-TR2-668	3/8 in x 3/8 in x 1/2 in
P-TR2-6610	3/8 in x 3/8 in x 5/8 in
P-TR2-686	3/8 in x 1/2 in x 3/8 in
P-TR2-6106	3/8 in x 5/8 in x 3/8 in
P-TR2-868	1/2 in x 3/8 in x 1/2 in
P-TR2-884	1/2 in x 1/2 in x 1/4 in
P-TR2-886	1/2 in x 1/2 in x 3/8 in
P-TR2-8810	1/2 in x 1/2 in x 5/8 in
P-TR2-10106	5/8 in x 5/8 in x 3/8 in
P-TR2-10108	5/8 in x 5/8 in x 1/2 in
P-TR2-10810	5/8 in x 1/2 in x 5/8 in

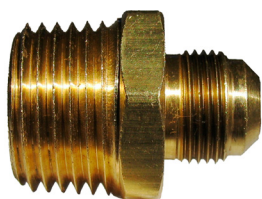

FOR REFERENCE ONLY -
SAE 010202

P-U1 CONNECTOR, TUBE TO MPT 48 SERIES

PART NUMBER	O.D. TUBE	PIPE THREAD SIZE
P-U1-2A	1/8 in	1/8 in
P-U1-3A	3/16 in	1/8 in
P-U1-4A	1/4 in	1/8 in
P-U1-4B	1/4 in	1/4 in
P-U1-4C	1/4 in	3/8 in
P-U1-4D	1/4 in	1/2 in
P-U1-5A	5/16 in	1/8 in
P-U1-5B	5/16 in	1/4 in
P-U1-5C	5/16 in	3/8 in
P-U1-6A	3/8 in	1/8 in
P-U1-6B	3/8 in	1/4 in
P-U1-6C	3/8 in	3/8 in
P-U1-6D	3/8 in	1/2 in
P-U1-6E	3/8 in	3/4 in
P-U1-8B	1/2 in	1/4 in
P-U1-8C	1/2 in	3/8 in
P-U1-8D	1/2 in	1/2 in
P-U1-8E	1/2 in	3/4 in
P-U1-10C	5/8 in	3/8 in
P-U1-10D	5/8 in	1/2 in
P-U1-10E	5/8 in	3/4 in
P-U1-12D	3/4 in	1/2 in
P-U1-12E	3/4 in	3/4 in
P-U1-14E	7/8 in	3/4 in

SAE 45° Flare

P-U2 UNION, TUBE BOTH ENDS 42 SERIES

PART NUMBER	O.D. TUBE
P-U2-3	3/16 in
P-U2-4	1/4 in
P-U2-5	5/16 in
P-U2-6	3/8 in
P-U2-8	1/2 in
P-U2-10	5/8 in
P-U2-12	3/4 in

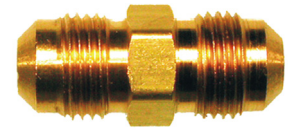

FOR REFERENCE ONLY -
SAE 010101

P-U3 ADAPTER, TUBE TO FPT 46 SERIES

PART NUMBER	O.D. TUBE FEMALE FLARE	PIPE THREAD SIZE
P-U3-3A	3/16 in	1/8 in
P-U3-4A	1/4 in	1/8 in
P-U3-4B	1/4 in	1/4 in
P-U3-4C	1/4 in	3/8 in
P-U3-5A	5/16 in	1/8 in
P-U3-5B	5/16 in	1/4 in
P-U3-6A	3/8 in	1/8 in
P-U3-6B	3/8 in	1/4 in
P-U3-6C	3/8 in	3/8 in
P-U3-6D	3/8 in	1/2 in
P-U3-6E	3/8 in	3/4 in
P-U3-8B	1/2 in	1/4 in
P-U3-8C	1/2 in	3/8 in
P-U3-8D	1/2 in	1/2 in
P-U3-8E	1/2 in	3/4 in
P-U3-10C	5/8 in	3/8 in
P-U3-10D	5/8 in	1/2 in
P-U3-10E	5/8 in	3/4 in
P-U3-12D	3/4 in	1/2 in
P-U3-12E	3/4 in	3/4 in

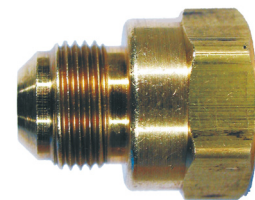

FOR REFERENCE ONLY -
SAE 010103

P-UR2 UNION, REDUCING TUBE BOTH ENDS 42 SERIES

PART NUMBER	O.D. TUBE
P-UR2-64	3/8 x 1/4 in
P-UR2-86	1/2 x 3/8 in
P-UR2-106	5/8 x 3/8 in
P-UR2-108	5/8 x 1/2 in
P-UR2-128	3/4 x 1/2 in
P-UR2-1210	3/4 x 5/8 in

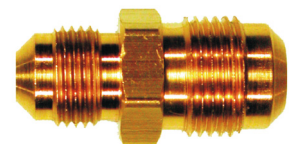

FOR REFERENCE ONLY -
SAE 010101



SAE 45° Flare

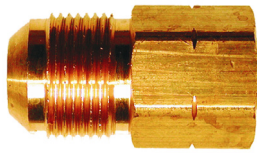

FOR REFERENCE ONLY -
SAE 010105

P-UR3 REDUCER, FEMALE FLARE TO MALE FLARE

PART NUMBER	O.D. TUBE FEMALE FLARE	O.D. TUBE MALE FLARE
P-UR3-46	1/4 in	3/8 in
P-UR3-64	3/8 in	1/4 in
P-UR3-68	3/8 in	1/2 in
P-UR3-86	1/2 in	3/8 in
P-UR3-810	1/2 in	5/8 in
P-UR3-108	5/8 in	1/2 in

Use with P-B2-Copper Gasket

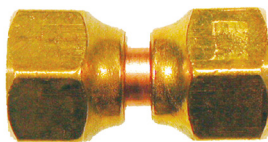

P-US4 SWIVEL CONNECTOR, FLARE BOTH ENDS

PART NUMBER	O.D. TUBE
P-US4-4	1/4 in x 1/4 in
P-US4-5	5/16 in x 5/16 in
P-US4-6	3/8 in x 3/8 in
P-US4-64	3/8 in x 1/4 in
P-US4-8	1/2 in x 1/2 in
P-US4-86	1/2 in x 3/8 in
P-US4-10	5/8 in x 5/8 in
P-US4-108	5/8 in x 1/2 in
P-US4-12	3/4 in x 3/4 in

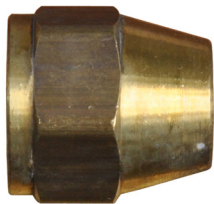

P-N1CT SPACE HEATER HUT

PART NUMBER	O.D. TUBE
P-N1CT-6	9/16-24



P-U1CT CONNECTOR, TUBE 9/16-24 TO MPT

PART NUMBER	PIPE THREAD SIZE
P-U1CT-6C	3/8 in X 3/8 in SP HTR UNION
P-U1CT-6D	3/8 in X 1/2 in SP HTR UNION

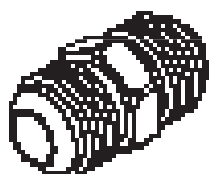

P-U2CT SPACE HEATER UNION, TUBE 9/26-24 TO TUBE 9/16-24

PART NUMBER	PIPE THREAD SIZE
P-U2CT-6	3/8 in SP HTR UNION

SAE 45° Flare

P-U3CT SPACE HEATER ADAPTER, TUBE 9-16-24 TO FPT

PART NUMBER	O.D. TUBE	PIPE THREAD SIZE
P-U3CT-6C	3/8 in	3/8 in
P-U3CT-6D	3/8 in	1/2 in

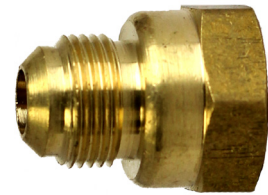

P-E3GA GAS APPLIANCE ADAPTER ELBOW, TUBE TO FPT

PART NUMBER	O.D. TUBE	PIPE THREAD SIZE
P-E3GA-10E	15/16 in	3/4 in



P-N5GA GAS APPLIANCE CAP

PART NUMBER	O.D. TUBE
P-N5GA-10	15/16 in.



P-U1GA CONNECTOR, TUBE 15/16 TO MPT

PART NUMBER	O.D. TUBE	PIPE THREAD SIZE
P-U1GA-10D	15/16 in	1/2 in
P-U1GA-10E	15/16 in	3/4 in

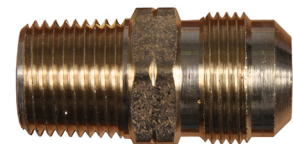

P-U3GA GAS APPLIANCE ADAPTER, TUBE TO FPT

PART NUMBER	O.D. TUBE	PIPE THREAD SIZE
P-U3GA-10E	15/16 in	3/4 in

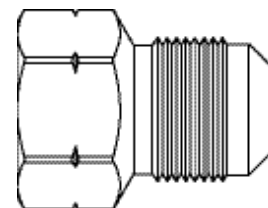



Inverted Flare

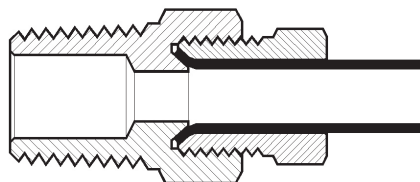
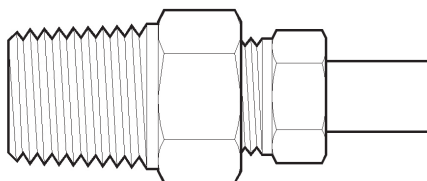

Tube O.D.	1/8	3/16	1/4	5/16	3/8	1/2	5/8	3/4
Thread Size	5/16-28	3/8-24	7/16-24	1/2-20	5/8-18	3/4-16	7/8-18	1-1/16-18

MATERIALS:

CA360, CA345
411S Nuts are zinc dichromate

VIBRATION RESISTANCE:

Good

WORKING PRESSURE:

2000 PSI Maximum based on tubing size.
ALWAYS consult tubing specifications.

TEMPERATURE RANGE:

-65 to +250°F
-54 to +121°C

CONFORMANCE:

Meets SAE, ASME and ASA Standards as noted by configuration.

APPLICATIONS:

Hydraulic brake lines, fuel lines, transmission oil cooler lines, and other applications where copper, brass, aluminum and steel tubing are used.

TUBING MUST BE ABLE TO BE FLARED.

HOW TO ORDER:

- Order nuts and bodies separately.
- Some items available on Special Order basis only.

NOMENCLATURE:

P-46I-6B

- 46I: Fitting Configuration
- 6: Tube Size in sixteenths ($6/16 = 3/8$)
- B: Pipe Thread Size in sixteenths ($2/16 = 1/4$)

Dimensions subject to change without notice

BENEFIT:

- Reduces maintenance costs and assembly time.
- Lowers maintenance frequency and costs.
- Reduces weight and size of systems.

FEATURE:

- Reusable body and nut.
- Resists mechanical pull-out.
- Compact tube bends.

ADVANTAGE:

- No need to replace when disassembling.
- Longer service life in vehicular applications.
- Fits tighter installation envelopes.

ASSEMBLY INSTRUCTIONS:

- Cut tubing squarely and remove burrs.
- Slide nut on tubing, threaded end out.
- Flare tubing.
- Lubricate threads.
- Position flare against the nose of the fitting.
- Assemble nut to body finger tight, plus 1/6 turn.

DO NOT OVER TIGHTEN OR TUBING MAY SPLIT

Inverted Flare

P-41IB NUT, BRASS

PART NUMBER	O.D. TUBE
P-41IB-4	1/4 in
P-41IB-5	5/16 in
P-41IB-6	3/8 in
P-41IB-8	1/2 in
P-41IB-10	5/8 in

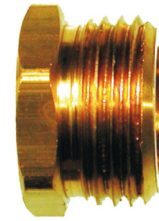

FOR REFERENCE ONLY -
SAE 040110

P-41IS NUT, ZINC DICHOMATE

PART NUMBER	O.D. TUBE
P-41IS-4	1/4 in
P-41IS-5	5/16 in
P-41IS-6	3/8 in



FOR REFERENCE ONLY -
SAE 040110

P-42I NUT, BRASS

PART NUMBER	O.D. TUBE
P-42I-3	3/16 in
P-42I-4	1/4 in
P-42I-5	5/16 in
P-42I-6	3/8 in
P-42I-8	1/2 in



FOR REFERENCE ONLY -
SAE 040101

P-46I ADAPTER, TUBE TO FPT

PART NUMBER	O.D. TUBE FEMALE FLARE	PIPE THREAD SIZE
P-46I-3A	3/16 in	1/8 in
P-46I-4A	1/4 in	1/8 in

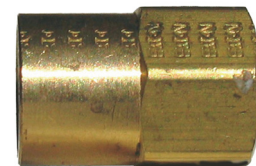

FOR REFERENCE ONLY -
SAE 040103



Inverted Flare

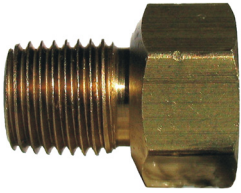

FOR REFERENCE ONLY -
SAE 040102

P-48I CONNECTOR, TUBE TO MPT

PART NUMBER	O.D. TUBE FEMALE FLARE	PIPE THREAD SIZE
P-48I-3A	3/16 in	1/8 in
P-48I-4A	1/4 in	1/8 in
P-48I-4B	1/4 in	1/4 in
P-48I-5A	5/16 in	1/8 in
P-48I-5B	5/16 in	1/4 in
P-48I-6A	3/8 in	1/8 in
P-48I-6B	3/8 in	1/4 in
P-48I-6C	3/8 in	3/8 in
P-48I-8B	1/2 in	1/4 in
P-48I-8C	1/2 in	3/8 in
P-48I-8D	1/2 in	1/2 in
P-48I-10D	5/8 in	1/2 in

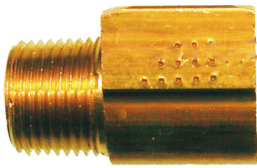

FOR REFERENCE ONLY -
SAE 040202

P-49I ELBOW, 90° TUBE TO MPT

PART NUMBER	O.D. TUBE FEMALE FLARE	PIPE THREAD SIZE
P-49I-3A	3/16 in	1/8 in
P-49I-4A	1/4 in	1/8 in
P-49I-4B	1/4 in	1/4 in
P-49I-5A	5/16 in	1/8 in
P-49I-5B	5/16 in	1/4 in
P-49I-6A	3/8 in	1/8 in
P-49I-6B	3/8 in	1/4 in
P-49I-6C	3/8 in	3/8 in
P-49I-8B	1/2 in	1/4 in
P-49I-8C	1/2 in	3/8 in
P-49I-8D	1/2 in	1/2 in
P-49I-10D	5/8 in	1/2 in

Pipe

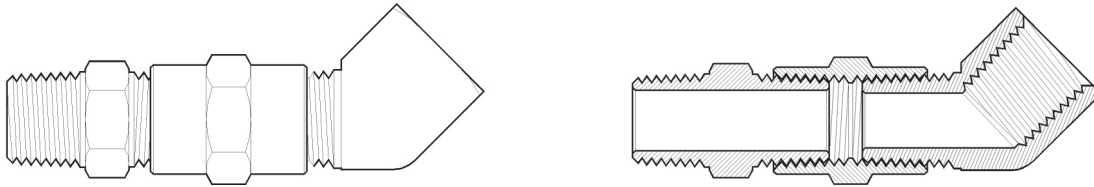

Tube O.D.	1/8	1/4	3/8	1/2	3/4	1
Thread Size	1/8-27	1/4-18	3/8-18	1/2-14	3/4-14	1-11 1/2

MATERIALS:

CA360, CA345, CA377

VIBRATION RESISTANCE:

Fair

WORKING PRESSURE:

1,200 PSI Maximum based on size.
ALWAYS consult tubing/pipe specifications.

TEMPERATURE RANGE:

-65 to +250°F
-54 to +121°C

CONFORMANCE:

Meets functional requirements of SAE as indicated by configuration.

APPLICATIONS:

Air, oil, water, hydraulic fluid, lubricant and other applications which use brass, copper, and iron pipe.

HOW TO ORDER:

- Item specific notes indicated throughout.
- Some items available on Special Order basis only.

NOMENCLATURE:

P-100A-A

- 100A: Fitting Configuration
- A: Pipe Size 1/8"
- Dimensions subject to change without notice.
- Contained in nomenclature indicates extruded style.

BENEFIT:

- Lowers costs based on fewer vendors.
- Reduces maintenance costs and unsightly leaks.
- More sales opportunities.

FEATURE:

- Wide range of sizes and styles.
- Extruded and Forged available.

ADVANTAGE:

- One-stop shop for all needs.
- Fewer leaks in the system.
- Conforms to more customers' requirements.

ASSEMBLY INSTRUCTIONS:

- Tighten male to female, finger tight.
- Tighten with a wrench as follows:

1/8" - 1/2"	2 Additional Turns
3/4" +	2-1/2 Additional Turns

DO NOT OVER TIGHTEN OR TUBING MAY SPLIT

Pipe



FOR REFERENCE ONLY -
SAE 130238

P-100A ELBOW, 90° FPT TO FPT

PART NUMBER	PIPE THREAD SIZE
P-100A-A	1/8 in
P-100A-B	1/4 in
P-100A-BA	1/4 in x 1/8 in
P-100A-C	3/8 in
P-100A-CB	3/8 in x 1/4 in
P-100A-D	1/2 in
P-100A-DC	1/2 in x 3/8 in
P-100A-E	3/4 in

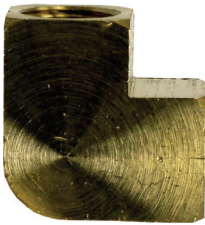

P-100X EXTRUDED ELBOW, 90° FPT TO FPT

PART NUMBER	PIPE THREAD SIZE
P-100X-A	1/8 in
P-100X-B	1/4 in
P-100X-C	3/8 in
P-100X-D	1/2 in
P-100X-E	3/4 in



P-100A-45 ELBOW, 45° FPT TO FPT

PART NUMBER	PIPE THREAD SIZE
P-100A-45-A	1/8 in
P-100A-45-B	1/4 in
P-100A-45-C	3/8 in

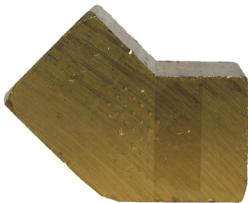

P-100X-45 EXTRUDED ELBOW, 45° FPT TO FPT

PART NUMBER	PIPE THREAD SIZE
P-100X-45-A	1/8 in
P-100X-45-B	1/4 in



FOR REFERENCE ONLY -
SAE 130438

P-101A TEE, FPT ALL ENDS

PART NUMBER	PIPE THREAD SIZE
P-101A-A	1/8 in
P-101A-B	1/4 in
P-101A-BBA	1/4 in x 1/4 in x 1/8 in
P-101A-C	3/8 in
P-101A-D	1/2 in
P-101A-DDC	1/2 in x 1/2 in x 3/8 in
P-101A-E	3/4 in

Pipe

P-101X EXTRUDED TEE, FPT ALL ENDS

PART NUMBER	PIPE THREAD SIZE
P-101X-A	1/8 in
P-101X-B	1/4 in
P-101X-C	3/8 in
P-101X-D	1/2 in
P-101X-E	3/4 in



P-102A CROSS, FPT ALL ENDS

PART NUMBER	PIPE THREAD SIZE
P-102A-A	1/8 in
P-102A-B	1/4 in
P-102A-C	3/8 in
P-102A-D	1/2 in



P-102X EXTRUDED CROSS, FPT ALL ENDS

PART NUMBER	PIPE THREAD SIZE
P-102X-A	1/8 in
P-102X-B	1/4 in
P-102X-C	3/8 in
P-102X-D	1/2 in



P-103A COUPLING, FPT TO FPT

PART NUMBER	PIPE THREAD SIZE
P-103A-A	1/8 in
P-103A-B	1/4 in
P-103A-C	3/8 in
P-103A-D	1/2 in
P-103A-E	3/4 in

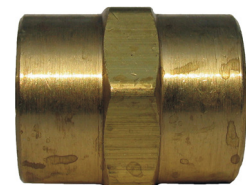

P-103AH COUPLING, FPT TO FPT HEAVY PATTERN

PART NUMBER	PIPE THREAD SIZE
P-103AH-A	1/8 in
P-103AH-B	1/4 in
P-103AH-C	3/8 in
P-103AH-D	1/2 in
P-103AH-E	3/4 in

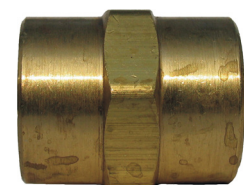

FOR REFERENCE ONLY -
SAE 130138



Pipe

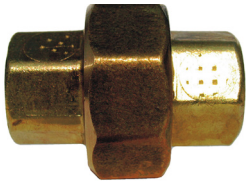

P-104A UNION, FPT TO FPT

PART NUMBER	PIPE THREAD SIZE
P-104A-A	1/8 in
P-104A-B	1/4 in
P-104A-C	3/8 in
P-104A-D	1/2 in
P-104A-E	3/4 in

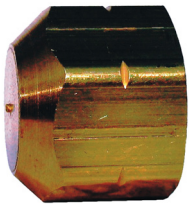

P-108A CAP

PART NUMBER	PIPE THREAD SIZE
P-108A-A	1/8 in
P-108A-B	1/4 in
P-108A-C	3/8 in
P-108A-D	1/2 in
P-108A-E	3/4 in



P-109A SQUARE HEAD PLUG, CORED

PART NUMBER	PIPE THREAD SIZE
P-109A-A	1/8 in
P-109A-B	1/4 in
P-109A-C	3/8 in
P-109A-D	1/2 in
P-109A-E	3/4 in
P-109A-F	1 in



P-109AS SQUARE HEAD PLUG, SOLID, MPT

PART NUMBER	PIPE THREAD SIZE
P-109AS-D	1/2 in
P-109AS-E	3/4 in
P-109AS-F	1 in

*SUPPLIED AS SOLID.



P-109CS COUNTER-SUNK PLUG, MPT

PART NUMBER	PIPE THREAD SIZE
P-109CS-A	1/8 in
P-109CS-B	1/4 in
P-109CS-C	3/8 in
P-109CS-D	1/2 in
P-109CS-E	3/4 in

Pipe

P-110A HEX BRUSHING, MPT TO FPT

PART NUMBER	PIPE THREAD SIZE
P-110A-BA	1/4 in x 1/8 in
P-110A-CA	3/8 in x 1/8 in
P-110A-CB	3/8 in x 1/4 in
P-110A-DA	1/2 in x 1/8 in
P-110A-DB	1/2 in x 1/4 in
P-110A-DC	1/2 in x 3/8 in
P-110A-EA	3/4 in x 1/8 in
P-110A-EB	3/4 in x 1/4 in
P-110A-EC	3/4 in x 3/8 in
P-110A-ED	3/4 in x 1/2 in
P-110A-FB	1 in x 1/4 in
P-110A-FC	1 in x 3/8 in
P-110A-FD	1 in x 1/2 in
P-110A-FE	1 in x 3/4 in



P-110AH HEX BRUSHING, MPT TO FPT HEAVY PATTERN

PART NUMBER	PIPE THREAD SIZE
P-110AH-BA	1/4 in x 1/8 in
P-110AH-CA	3/8 in x 1/8 in
P-110AH-CB	3/8 in x 1/4 in
P-110AH-DA	1/2 in x 1/8 in
P-110AH-DB	1/2 in x 1/4 in
P-110AH-DC	1/2 in x 3/8 in
P-110AH-EA	3/4 in x 1/8 in
P-110AH-EB	3/4 in x 1/4 in
P-110AH-EC	3/4 in x 3/8 in
P-110AH-ED	3/4 in x 1/2 in



FOR REFERENCE ONLY -
SAE 130140

P-110FB FACE BUSHING, MPT TO FPT

PART NUMBER	PIPE THREAD SIZE
P-110FB-CB	3/8 in x 1/4 in
P-110FB-DB	1/2 in x 1/4 in
P-110FB-DC	1/2 in x 3/8 in
P-110FB-ED	3/4 in x 1/2 in



Pipe



P-111A LOCK NUT

PART NUMBER	PIPE THREAD SIZE
P-111A-A	1/8 in
P-111A-B	1/4 in
P-111A-C	3/8 in
P-111A-D	1/2 in
P-111A-E	3/4 in

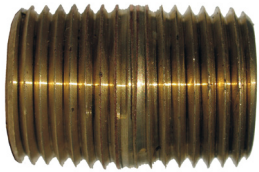

P-112A CLOSE NIPPLE

PART NUMBER	PIPE THREAD SIZE
P-112A-A	1/8 in
P-112A-B	1/4 in
P-112A-C	3/8 in
P-112A-D	1/2 in
P-112A-E	3/4 in
P-112A-F	1 in



P-113A LONG NIPPLE YELLOW BRASS

PART NUMBER	PIPE THREAD SIZE	LENGTH
P-113A-A15	1/8 in	1-1/2 in
P-113A-B15	1/4 in	1-1/2 in
P-113A-C15	3/8 in	1-1/2 in
P-113A-D15	1/2 in	1-1/2 in
P-113A-E15	3/4 in	1-1/2 in
P-113A-A2	1/8 in	2 in
P-113A-B2	1/4 in	2 in
P-113A-C2	3/8 in	2 in
P-113A-D2	1/2 in	2 in
P-113A-E2	3/4 in	2 in

Pipe

P-113RB LONG NIPPLE RED BRASS

PART NUMBER	PIPE THREAD SIZE	LENGTH	PART NUMBER	PIPE THREAD SIZE	LENGTH
P-113RB-A25	1/8 in	2-1/2 in	P-113RB-A5	1/8 in	5 in
P-113RB-B25	1/4 in	2-1/2 in	P-113RB-B5	1/4 in	5 in
P-113RB-C25	3/8 in	2-1/2 in	P-113RB-C5	3/8 in	5 in
P-113RB-D25	1/2 in	2-1/2 in	P-113RB-D5	1/2 in	5 in
P-113RB-E25	3/4 in	2-1/2 in	P-113RB-E5	3/4 in	5 in
P-113RB-A3	1/8 in	3 in	P-113RB-A55	1/8 in	5-1/2 in
P-113RB-B3	1/4 in	3 in	P-113RB-B55	1/4 in	5-1/2 in
P-113RB-C3	3/8 in	3 in	P-113RB-C55	3/8 in	5-1/2 in
P-113RB-D3	1/2 in	3 in	P-113RB-D55	1/2 in	5-1/2 in
P-113RB-E3	3/4 in	3 in	P-113RB-E55	3/4 in	5-1/2 in
P-113RB-A35	1/8 in	3-1/2 in	P-113RB-A6	1/8 in	6 in
P-113RB-B35	1/4 in	3-1/2 in	P-113RB-B6	1/4 in	6 in
P-113RB-C35	3/8 in	3-1/2 in	P-113RB-C6	3/8 in	6 in
P-113RB-D35	1/2 in	3-1/2 in	P-113RB-D6	1/2 in	6 in
P-113RB-E35	3/4 in	3-1/2 in	P-113RB-E6	3/4 in	6 in
P-113RB-A4	1/8 in	4 in	P-113RB-A7	1/8 in	7 in
P-113RB-B4	1/4 in	4 in	P-113RB-B7	1/4 in	7 in
P-113RB-C4	3/8 in	4 in	P-113RB-C7	3/8 in	7 in
P-113RB-D4	1/2 in	4 in	P-113RB-D7	1/2 in	7 in
P-113RB-E4	3/4 in	4 in	P-113RB-E7	3/4 in	7 in
P-113RB-A45	1/8 in	4-1/2 in			
P-113RB-B45	1/4 in	4-1/2 in			
P-113RB-C45	3/8 in	4-1/2 in			
P-113RB-D45	1/2 in	4-1/2 in			
P-113RB-E45	3/4 in	4-1/2 in			



P-116A STREET ELBOW, 90° MPT TO FPT

PART NUMBER	PIPE THREAD SIZE
P-116A-A	1/8 in
P-116A-B	1/4 in
P-116A-C	3/8 in
P-116A-D	1/2 in
P-116A-E	3/4 in

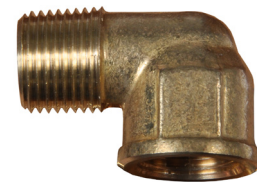

FOR REFERENCE ONLY -
SAE 130239

Pipe

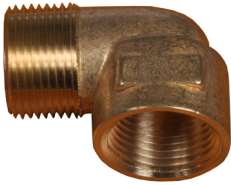

P-116AL STREET ELBOW, 90° MPT TO FPT LONG PATTERN

PART NUMBER	PIPE THREAD SIZE
P-116AL-A	1/8 in
P-116AL-B	1/4 in
P-116AL-C	3/8 in



P-116AM MALE ELBOW, MPT TO MPT

PART NUMBER	PIPE THREAD SIZE
P-116AM-A	1/8 in
P-116AM-B	1/4 in
P-116AM-BA	1/4 in x 1/8 in
P-116AM-C	3/8 in
P-116AM-CB	3/8 in x 1/4 in
P-116AM-D	1/2 in
P-116AM-DC	1/2 in x 3/8 in

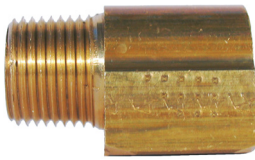

FOR REFERENCE ONLY -
SAE 130239

P-116X STREET ELBOW, 90° MPT TO FPT

PART NUMBER	PIPE THREAD SIZE
P-116X-A	1/8 in
P-116X-B	1/4 in
P-116X-C	3/8 in
P-116X-D	1/2 in
P-116X-E	3/4 in



P-117A SLOTTED PLUG, MPT

PART NUMBER	PIPE THREAD SIZE
P-117A-A	1/8 in
P-117A-B	1/4 in
P-117A-C	3/8 in

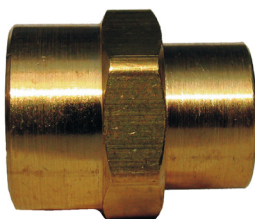

P-119A REDUCER, FPT TO FPT

PART NUMBER	PIPE THREAD SIZE
P-119A-BA	1/4 in x 1/8 in
P-119A-CA	3/8 in x 1/8 in
P-119A-CB	3/8 in x 1/4 in
P-119A-DA	1/2 in x 1/8 in
P-119A-DB	1/2 in x 1/4 in
P-119A-DC	1/2 in x 3/8 in
P-119A-ED	3/4 in x 1/2 in

Pipe

P-119AH REDUCER, FPT TO FPT HEAVY PATTERN

PART NUMBER	PIPE THREAD SIZE
P-119AH-BA	1/4 in x 1/8 in
P-119AH-CB	3/8 in x 1/4 in
P-119AH-DB	1/2 in x 1/4 in
P-119AH-DC	1/2 in x 3/8 in

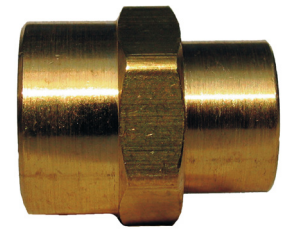

FOR REFERENCE ONLY -
SAE 130138

P-120A ADAPTER, FPT TO MPT

PART NUMBER	PIPE THREAD SIZE
P-120A-AA	1/8 in x 1/8 in
P-120A-BA	1/4 in x 1/8 in
P-120A-BB	1/4 in x 1/4 in
P-120A-CA	3/8 in x 1/8 in
P-120A-CB	3/8 in x 1/4 in
P-120A-CC	3/8 in x 3/8 in
P-120A-DB	1/2 in x 1/4 in
P-120A-DC	1/2 in x 3/8 in
P-120A-DD	1/2 in x 1/2 in
P-120A-ED	3/4 in x 1/2 in

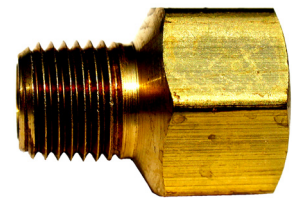

P-120AH ADAPTER, FPT TO MPT HEAVY PATTERN

PART NUMBER	PIPE THREAD SIZE
P-120AH-AA	1/8 in x 1/8 in
P-120AH-BA	1/4 in x 1/8 in
P-120AH-BB	1/4 in x 1/4 in
P-120AH-CB	3/8 in x 1/4 in
P-120AH-CC	3/8 in x 3/8 in
P-120AH-DB	1/2 in x 1/4 in
P-120AH-DC	1/2 in x 3/8 in
P-120AH-DD	1/2 in x 1/2 in

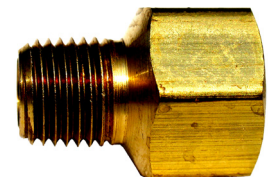

FOR REFERENCE ONLY -
SAE 130139

P-121A HEX HEAD PLUG, CORED

PART NUMBER	PIPE THREAD SIZE
P-121A-A	1/8 in
P-121A-B	1/4 in
P-121A-C	3/8 in
P-121A-D	1/2 in
P-121A-E	3/4 in
P-121A-F	1 in



Pipe



P-121AS HEX HEAD PLUG, SOLID

PART NUMBER	PIPE THREAD SIZE
P-121AS-A	1/8 in
P-121AS-B	1/4 in
P-121AS-C	3/8 in
P-121AS-D	1/2 in
P-121AS-E	3/4 in

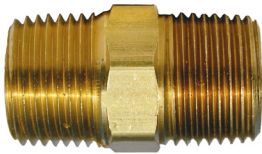

P-122A HEX NIPPLE, MPT TO MPT

PART NUMBER	PIPE THREAD SIZE
P-122A-A	1/8 in
P-122A-B	1/4 in
P-122A-C	3/8 in
P-122A-D	1/2 in
P-122A-E	3/4 in

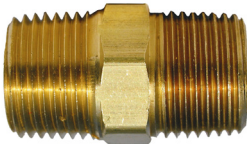

P-122AH HEX NIPPLE, MPT TO MPT HEAVY PATTERN

PART NUMBER	PIPE THREAD SIZE
P-122AH-A	1/8 in
P-122AH-B	1/4 in
P-122AH-C	3/8 in
P-122AH-D	1/2 in
P-122AH-E	3/4 in

FOR REFERENCE ONLY -
SAE 130137

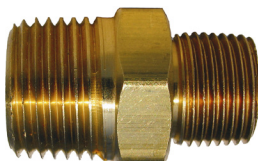

P-123A HEX REDUCING NIPPLE, MPT TO MPT

PART NUMBER	PIPE THREAD SIZE
P-123A-BA	1/4 in x 1/8 in
P-123A-CA	3/8 in x 1/8 in
P-123A-CB	3/8 in x 1/4 in
P-123A-DB	1/2 in x 1/4 in
P-123A-DC	1/2 in x 3/8 in
P-123A-ED	3/4 in x 1/2 in

Pipe

P-123AH HEX REDUCING NIPPLE, MPT TO MPT HEAVY PATTERN

PART NUMBER	PIPE THREAD SIZE
P-123AH-BA	1/4 in x 1/8 in
P-123AH-CA	3/8 in x 1/8 in
P-123AH-CB	3/8 in x 1/4 in
P-123AH-DB	1/2 in x 1/4 in
P-123AH-DC	1/2 in x 3/8 in

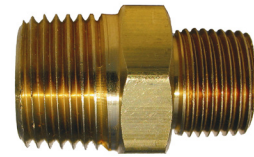

FOR REFERENCE ONLY -
SAE 130137

P-124A STREET ELBOW, 45° MPT TO FPT

PART NUMBER	PIPE THREAD SIZE
P-124A-A	1/8 in
P-124A-B	1/4 in
P-124A-C	3/8 in
P-124A-D	1/2 in

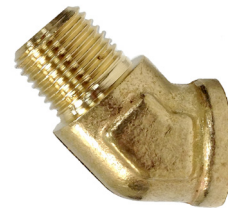

FOR REFERENCE ONLY -
SAE 130339

P-124X STREET ELBOW, 45° MPT TO FPT

PART NUMBER	PIPE THREAD SIZE
P-124X-A	1/8 in
P-124X-B	1/4 in
P-124X-C	3/8 in
P-124X-D	1/2 in

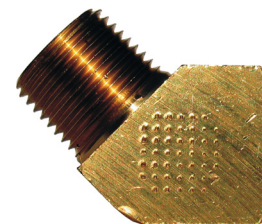

FOR REFERENCE ONLY -
SAE 130339

P-127A STREET TEE, FPT TO MPT TO FPT

PART NUMBER	PIPE THREAD SIZE
P-127A-A	1/8 in
P-127A-B	1/4 in
P-127A-C	3/8 in
P-127A-D	1/2 in

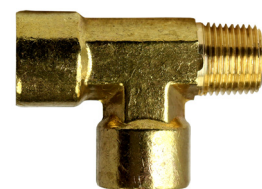

FOR REFERENCE ONLY -
SAE 130424



Pipe

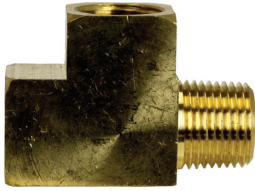

FOR REFERENCE ONLY -
SAE 130424

P-127X STREET TEE, FPT TO MPT TO FPT

PART NUMBER	PIPE THREAD SIZE
P-127X-A	1/8 in
P-127X-B	1/4 in
P-127X-C	3/8 in
P-127X-D	1/2 in



P-128A REDUCING ELBOW, FPT TO MPT

PART NUMBER	PIPE THREAD SIZE
P-128A-BA	1/4 in x 1/8 in
P-128A-BC	1/4 in x 3/8 in
P-128A-CB	3/8 in x 1/4 in

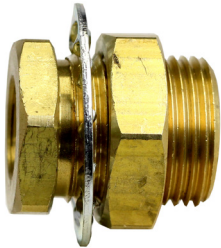

P-129A COUPLING, FPT TO STRAIGHT THREAD

PART NUMBER	FEMALE PIPE THREAD SIZE	STRAIGHT THREAD SIZE
P-129A-A	1/8 in	5/8-18
P-129AS-B (Short)	1/4 in	3/4-16
P-129A-B	1/4 in	3/4-16
P-129A-C	3/8 in	1-14
P-129A-D	1/2 in	1 1/8-14



FOR REFERENCE ONLY -
SAE 130425

P-T9 BRANCH TEE, FPT TO FPT TO MPT

PART NUMBER	PIPE THREAD SIZE
P-T9-222	1/8 in
P-T9-444	1/4 in
P-T9-666	3/8 in
P-T9-888	1/2 in

Pipe

RED BRASS FITTINGS

Construction: Materials CA230 or CA314

Applications: Used for water, oil, steam, air and gas.

Advantages: Improved resistance to corrosion for aggressive environments.

P-100RB ELBOW, 90° FPT TO FPT

PART NUMBER	PIPE THREAD SIZE
P-100RB-A	1/8 in
P-100RB-B	1/4 in
P-100RB-C	3/8 in
P-100RB-D	1/2 in
P-100RB-E	3/4 in
P-100RB-F	1 in



P-100-45RB ELBOW, 45° FPT TO FPT

PART NUMBER	PIPE THREAD SIZE
P-100-45RB-A	1/8 in
P-100-45RB-B	1/4 in
P-100-45RB-C	3/8 in
P-100-45RB-D	1/2 in
P-100-45RB-E	3/4 in
P-100-45RB-F	1 in



P-101RB TEE, FPT ALL ENDS

PART NUMBER	PIPE THREAD SIZE
P-101RB-A	1/8 in
P-101RB-B	1/4 in
P-101RB-C	3/8 in
P-101RB-D	1/2 in
P-101RB-E	3/4 in
P-101RB-F	1 in

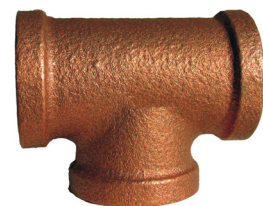

P-103RB COUPLING, FPT TO FPT

PART NUMBER	PIPE THREAD SIZE
P-103RB-A	1/8 in
P-103RB-B	1/4 in
P-103RB-C	3/8 in
P-103RB-D	1/2 in
P-103RB-E	3/4 in
P-103RB-F	1 in

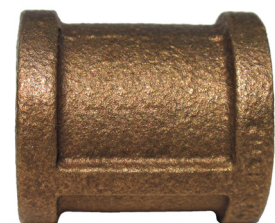



Pipe

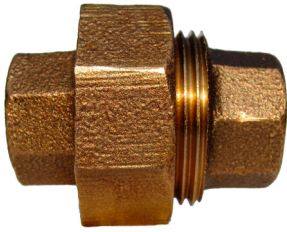

P-104RB GROUND JOINT UNION, FPT TO FPT

PART NUMBER	PIPE THREAD SIZE
P-104RB-A	1/8 in
P-104RB-B	1/4 in
P-104RB-C	3/8 in
P-104RB-D	1/2 in
P-104RB-E	3/4 in
P-104RB-F	1 in



P-108RB CAP, FPT

PART NUMBER	PIPE THREAD SIZE
P-108RB-A	1/8 in
P-108RB-B	1/4 in
P-108RB-C	3/8 in
P-108RB-D	1/2 in
P-108RB-E	3/4 in
P-108RB-F	1 in

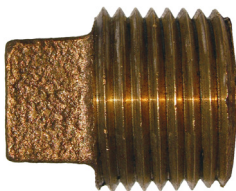

P-109RB SQUARE HEAD PLUG, MPT

PART NUMBER	PIPE THREAD SIZE
P-109RB-A	1/8 in
P-109RB-B	1/4 in
P-109RB-C	3/8 in
P-109RB-D	1/2 in
P-109RB-E	3/4 in
P-109RB-F	1 in



P-110FRB FACE BUSHING, MPT TO FPT

PART NUMBER	PIPE THREAD SIZE
P-110FRB-DC	1/2 in x 3/8 in
P-110FRB-ED	3/4 in x 1/2 in



P-110RB HEX BRUSHING, MPT TO FPT

PART NUMBER	PIPE THREAD SIZE
P-110RB-BA	1/4 in x 1/8 in
P-110RB-CB	3/8 in x 1/4 in
P-110RB-DC	1/2 in x 3/8 in
P-110RB-ED	3/4 in x 1/2 in
P-110RB-FE	1 in x 3/4 in

Pipe

P-112RB CLOSE NIPPLE, MPT TO MPT

PART NUMBER	PIPE THREAD SIZE
P-112RB-A	1/8 in
P-112RB-B	1/4 in
P-112RB-C	3/8 in
P-112RB-D	1/2 in
P-112RB-E	3/4 in
P-112RB-F	1 in



P-116RB STREET ELBOW, 90° MPT TO FPT

PART NUMBER	PIPE THREAD SIZE
P-116RB-A	1/8 in
P-116RB-B	1/4 in
P-116RB-C	3/8 in
P-116RB-D	1/2 in
P-116RB-E	3/4 in
P-116RB-F	1 in

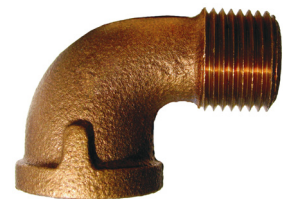

P-119RB REDUCER, FPT TO FPT

PART NUMBER	PIPE THREAD SIZE
P-119RB-DB	1/2 in x 1/4 in
P-119RB-DC	1/2 in x 3/8 in
P-119RB-EC	3/4 in x 3/8 in
P-119RB-ED	3/4 in x 1/2 in
P-119RB-FE	1 in x 3/4 in

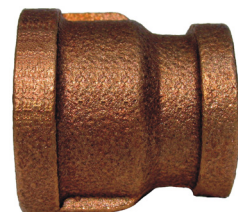

P-124RB STREET ELBOW, 45° MPT TO FPT

PART NUMBER	PIPE THREAD SIZE
P-124RB-D	1/2 in
P-124RB-E	3/4 in



P-125RB DROP EAR PIPE ELBOW, FPT TO FPT

PART NUMBER	PIPE THREAD SIZE
P-125RB-D	1/2 in

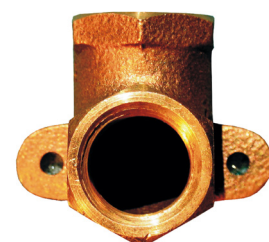



Pipe



P-113RB LONG NIPPLE RED BRASS

PART NUMBER	PIPE THREAD SIZE	LENGTH
P-113RB-A25	1/8 in	2-1/2 in
P-113RB-B25	1/4 in	2-1/2 in
P-113RB-C25	3/8 in	2-1/2 in
P-113RB-D25	1/2 in	2-1/2 in
P-113RB-E25	3/4 in	2-1/2 in
P-113RB-A3	1/8 in	3 in
P-113RB-B3	1/4 in	3 in
P-113RB-C3	3/8 in	3 in
P-113RB-D3	1/2 in	3 in
P-113RB-E3	3/4 in	3 in
P-113RB-A35	1/8 in	3-1/2 in
P-113RB-B35	1/4 in	3-1/2 in
P-113RB-C35	3/8 in	3-1/2 in
P-113RB-D35	1/2 in	3-1/2 in
P-113RB-E35	3/4 in	3-1/2 in
P-113RB-A4	1/8 in	4 in
P-113RB-B4	1/4 in	4 in
P-113RB-C4	3/8 in	4 in
P-113RB-D4	1/2 in	4 in
P-113RB-E4	3/4 in	4 in
P-113RB-A45	1/8 in	4-1/2 in
P-113RB-B45	1/4 in	4-1/2 in
P-113RB-C45	3/8 in	4-1/2 in
P-113RB-D45	1/2 in	4-1/2 in
P-113RB-E45	3/4 in	4-1/2 in
P-113RB-A5	1/8 in	5 in
P-113RB-B5	1/4 in	5 in
P-113RB-C5	3/8 in	5 in
P-113RB-D5	1/2 in	5 in
P-113RB-E5	3/4 in	5 in
P-113RB-A55	1/8 in	5-1/2 in
P-113RB-B55	1/4 in	5-1/2 in
P-113RB-C55	3/8 in	5-1/2 in
P-113RB-D55	1/2 in	5-1/2 in
P-113RB-E55	3/4 in	5-1/2 in

PART NUMBER	PIPE THREAD SIZE	LENGTH
P-113RB-A6	1/8 in	6 in
P-113RB-B6	1/4 in	6 in
P-113RB-C6	3/8 in	6 in
P-113RB-D6	1/2 in	6 in
P-113RB-E6	3/4 in	6 in
P-113RB-A7	1/8 in	7 in
P-113RB-B7	1/4 in	7 in
P-113RB-C7	3/8 in	7 in
P-113RB-D7	1/2 in	7 in
P-113RB-E7	3/4 in	7 in

Compression

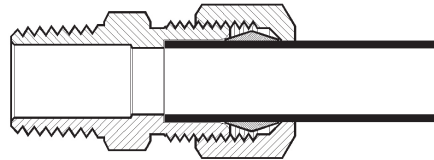
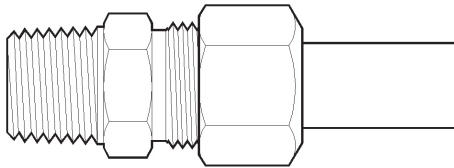

Tube O.D.	1/8	3/16	1/4	5/16	3/8	7/16	1/2	5/8	3/4	1
Thread	5/16-24	3/8-24	7/16-24	1/2-24	9/16-24	5/8-24	11/16-20	13/16-18	1-18	1-1/8-18

MATERIALS:

CA360, CA345, CA377, C2680

VIBRATION RESISTANCE:

Short Nut - Fair, Long Nut - Improved

WORKING PRESSURE:

400 PSI Maximum based on tubing size.
ALWAYS consult tubing specifications.

TEMPERATURE RANGE:

-65 to +212°F
-54 to +100°C

CONFORMANCE:

Meets functional requirements of SAE as indicated by configuration.

APPLICATIONS:

Air, oil, water, lubricant and other applications which use brass, copper, aluminum and thermoplastic tubing. Use of thermoplastic tubing requires a brass insert (Fitting Configuration P-60AE).

HOW TO ORDER:

- Supplied as three piece assemblies including body, nut and sleeve.
- For body only, use "B" prefix.
- Some items available on Special Order basis only.

NOMENCLATURE:

P-68A-6B

- 68A: Fitting Configuration
- 6: Tube Size in sixteenths (6/16 = 3/8)
- B: Pipe Size 1/4"
- Dimensions subject to change without notice

BENEFIT:

- Reduces maintenance costs and assembly time.
- Lower costs based on fewer vendors.
- More sales opportunities.

FEATURE:

- No special tube prep required.
- Wide range of sizes and styles.
- Extruded and Forged available.

ADVANTAGE:

- Faster, more reliable assembly.
- One-stop shop for all needs.
- Conforms to more customers' requirements.

ASSEMBLY INSTRUCTIONS:

- Cut tubing squarely and remove burrs.
- Slide nut and sleeve on tubing, threaded end out.
- Insert the tube into fitting until it bottoms.
- Lubricate threads.
- Assemble nut to body finger tight.
- Tighten with a wrench as follows:
1/8" - 5/16": 1-1/4 Additional Turns
3/8" - 7/8": 2-1/4 Additional Turns

DO NOT OVER TIGHTEN OR TUBING MAY SPLIT



Compression



FOR REFERENCE ONLY -
SAE 060115

P-60A SLEEVE

PART NUMBER	O.D. TUBE
P-60A-2	1/8 in
P-60A-3	3/16 in
P-60A-4	1/4 in
P-60A-5	5/16 in
P-60A-6	3/8 in
P-60A-7	7/16 in
P-60A-8	1/2 in
P-60A-10	5/8 in
P-60A-12	3/4 in
P-60A-14	7/8 in



P-60AE BRASS INSERT

PART NUMBER	O.D. TUBE
P-60AE-4	1/4 in
P-60AE-5	5/16 in
P-60AE-6	3/8 in
P-60AE-8	1/2 in
P-60AE-10	5/8 in

FOR USE WITH SOFT TUBING



P-60AP DERLIN SLEEVE

PART NUMBER	O.D. TUBE
P-60AP-4	1/4 in
P-60AP-5	5/16 in
P-60AP-6	3/8 in
P-60AP-8	1/2 in
P-60AP-10	5/8 in



FOR REFERENCE ONLY -
SAE 060110

P-61A NUT

PART NUMBER	O.D. TUBE
P-61A-2	1/8 in
P-61A-3	3/16 in
P-61A-4	1/4 in
P-61A-5	5/16 in
P-61A-6	3/8 in
P-61AC-6 (Chrome)	3/8 in
P-61A-7	7/16 in
P-61A-8	1/2 in
P-61A-10	5/8 in
P-61A-12	3/4 in
P-61A-14	7/8 in

Compression

P-161A NUT, LONG

PART NUMBER	O.D. TUBE
P-161A-4	1/4 in
P-161A-5	5/16 in
P-161A-6	3/8 in



FOR REFERENCE ONLY -
SAE 060111

P-62A UNION, TUBE BOTH ENDS

PART NUMBER	O.D. TUBE
P-62A-22	1/8 in
P-62A-33	3/16 in
P-62A-42	1/4 in x 1/8 in
P-62A-43	1/4 in x 3/16 in
P-62A-44	1/4 in
P-62A-54	5/16 in x 1/4 in
P-62A-55	5/16 in
P-62A-64	3/8 in x 1/4 in
P-62A-65	3/8 in x 5/16 in
P-62A-66	3/8 in
P-62A-86	1/2 in x 3/8 in
P-62A-88	1/2 in
P-62A-106	5/8 in x 3/8 in
P-62A-108	5/8 in x 1/2 in
P-62A-1010	5/8 in
P-62A-1212	3/4 in
P-62A-1414	7/8 in

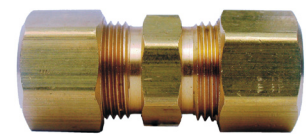

FOR REFERENCE ONLY -
SAE 060101BA

P-64A TEE, TUBE ALL ENDS

PART NUMBER	O.D. TUBE
P-64A-22	1/8 in
P-64A-33	3/16 in
P-64A-44	1/4 in
P-64A-55	5/16 in
P-64A-664	3/8 in x 3/8 in x 1/4 in
P-64A-66	3/8 in
P-64A-88	1/2 in
P-64A-1010	5/8 in
P-64A-1212	3/4 in
P-64A-1414*	7/8 in

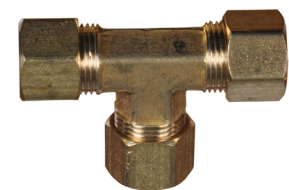

FOR REFERENCE ONLY -
SAE 060401



Compression

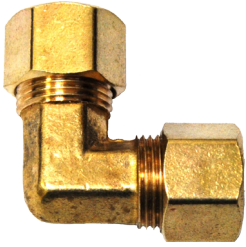

FOR REFERENCE ONLY -
SAE 060201

P-65A ELBOW, TUBE BOTH ENDS

PART NUMBER	O.D. TUBE
P-65A-33	3/16 in
P-65A-44	1/4 in
P-65A-55	5/16 in
P-65A-64	3/8 in x 1/4 in
P-65A-66	3/8 in
P-65A-88	1/2 in
P-65A-1010	5/8 in
P-65A-106	5/8 in x 3/8 in
P-65A-108	5/8 in x 1/2 in
P-65A-1212	3/4 in
P-65A-1414	7/8 in

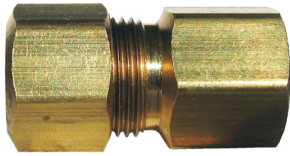

FOR REFERENCE ONLY -
SAE 060103

P-66A ADAPTER, TUBE TO FPT

PART NUMBER	O.D. TUBE	PIPE THREAD SIZE
P-66A-2A	1/8 in	1/8 in
P-66A-3A	3/16 in	1/8 in
P-66A-3B	3/16 in	1/4 in
P-66A-4A	1/4 in	1/8 in
P-66A-4B	1/4 in	1/4 in
P-66A-4C	1/4 in	3/8 in
P-66A-4D	1/4 in	1/2 in
P-66A-5A	5/16 in	1/8 in
P-66A-5B	5/16 in	1/4 in
P-66A-5C	5/16 in	3/8 in
P-66A-6A	3/8 in	1/8 in
P-66A-6B	3/8 in	1/4 in
P-66A-6C	3/8 in	3/8 in
P-66A-6D	3/8 in	1/2 in
P-66A-6E	3/8 in	3/4 in
P-66A-8B	1/2 in	1/4 in
P-66A-8C	1/2 in	3/8 in
P-66A-8D	1/2 in	1/2 in
P-66A-10C	5/8 in	3/8 in
P-66A-10D	5/8 in	1/2 in
P-66A-10E	5/8 in	3/4 in
P-66A-12D	3/4 in	1/2 in
P-66A-12E	3/4 in	3/4 in
P-66A-14E	7/8 in	3/4 in

Compression

P-68A CONNECTOR, TUBE TO MPT

PART NUMBER	O.D. TUBE	PIPE THREAD SIZE
P-68A-2A	1/8 in	1/8 in
P-68A-3A	3/16 in	1/8 in
P-68A-3B	3/16 in	1/4 in
P-68A-4A	1/4 in	1/8 in
P-68A-4B	1/4 in	1/4 in
P-68A-4C	1/4 in	3/8 in
P-68A-4D	1/4 in	1/2 in
P-68A-5A	5/16 in	1/8 in
P-68A-5B	5/16 in	1/4 in
P-68A-5C	5/16 in	3/8 in
P-68A-6A	3/8 in	1/8 in
P-68A-6B	3/8 in	1/4 in
P-68A-6C	3/8 in	3/8 in
P-68A-6D	3/8 in	1/2 in
P-68A-6E	3/8 in	3/4 in
P-68A-8B	1/2 in	1/4 in
P-68A-8C	1/2 in	3/8 in
P-68A-8D	1/2 in	1/2 in
P-68A-8E	1/2 in	3/4 in
P-68A-10C	5/8 in	3/8 in
P-68A-10D	5/8 in	1/2 in
P-68A-10E	5/8 in	3/4 in
P-68A-12D	3/4 in	1/2 in
P-68A-12E	3/4 in	3/4 in
P-68A-14D	7/8 in	1/2 in
P-68A-14E	7/8 in	3/4 in

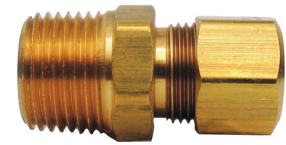

FOR REFERENCE ONLY -
SAE 060102BA

P-6945A ELBOW, 45° TUBE TO MPT

PART NUMBER	O.D. TUBE	PIPE THREAD SIZE
P-6945A-4A	1/4 in	1/8 in
P-6945A-6B	3/8 in	1/4 in
P-6945A-8C	1/2 in	3/8 in
P-6945A-10D	5/8 in	1/2 in





Compression

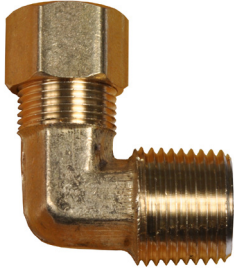

FOR REFERENCE ONLY -
SAE 060202BA

P-69A ELBOW, 90° TUBE TO MPT

PART NUMBER	O.D. TUBE	PIPE THREAD SIZE
P-69A-2A	1/8 in	1/8 in
P-69A-3A	3/16 in	1/8 in
P-69A-4A	1/4 in	1/8 in
P-69A-4B	1/4 in	1/4 in
P-69A-4C	1/4 in	3/8 in
P-69A-4D	1/4 in	1/2 in
P-69A-5A	5/16 in	1/8 in
P-69A-5B	5/16 in	1/4 in
P-69A-5C	5/16 in	3/8 in
P-69A-6A	3/8 in	1/8 in
P-69A-6B	3/8 in	1/4 in
P-69A-6C	3/8 in	3/8 in
P-69A-6D	3/8 in	1/2 in
P-69A-6E	3/8 in	3/4 in
P-69A-7B	7/16 in	1/4 in
P-69A-8B	1/2 in	1/4 in
P-69A-8C	1/2 in	3/8 in
P-69A-8D	1/2 in	1/2 in
P-69A-8E	1/2 in	3/4 in
P-69A-10C	5/8 in	3/8 in
P-69A-10D	5/8 in	1/2 in
P-69A-10E	5/8 in	3/4 in
P-69A-12D	3/4 in	1/2 in
P-69A-12E	3/4 in	3/4 in
P-69A-14E	7/8 in	3/4 in

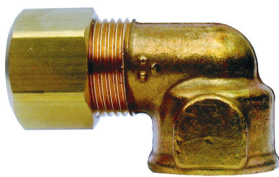

FOR REFERENCE ONLY -
SAE 060203BA

P-70A ELBOW, 90° TUBE TO FPT

PART NUMBER	O.D. TUBE	PIPE THREAD SIZE
P-70A-4A	1/4 in	1/8 in
P-70A-4B	1/4 in	1/4 in
P-70A-4C	1/4 in	3/8 in
P-70A-5A	5/16 in	1/8 in
P-70A-5B	5/16 in	1/4 in
P-70A-6A	3/8 in	1/8 in
P-70A-6B	3/8 in	1/4 in
P-70A-6C	3/8 in	3/8 in
P-70A-6D	3/8 in	1/2 in
P-70A-8B	1/2 in	1/4 in
P-70A-8C	1/2 in	3/8 in
P-70A-8D	1/2 in	1/2 in
P-70A-8E	1/2 in	3/4 in
P-70A-10C	5/8 in	3/8 in
P-70A-10D	5/8 in	1/2 in
P-70A-10E	5/8 in	3/4 in
P-70A-12D	3/4 in	1/2 in
P-70A-12E	3/4 in	3/4 in

Compression

P-71A MALE RUN TEE, TUBE TO MPT TO TUBE

PART NUMBER	O.D. TUBE	PIPE THREAD SIZE
P-71A-2A	1/8 in	1/8 in
P-71A-3A	3/16 in	1/8 in
P-71A-4A	1/4 in	1/8 in
P-71A-4B	1/4 in	1/4 in
P-71A-5A	5/16 in	1/8 in
P-71A-5B	5/16 in	1/4 in
P-71A-6A	3/8 in	1/8 in
P-71A-6B	3/8 in	1/4 in
P-71A-6C	3/8 in	3/8 in
P-71A-8C	1/2 in	3/8 in
P-71A-8D	1/2 in	1/2 in
P-71A-10D	5/8 in	1/2 in
P-71A-12D	3/4 in	1/2 in

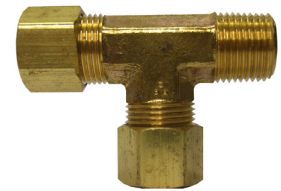

P-72A MALE BRANCH TEE, TUBE TO MPT TO TUBE

PART NUMBER	O.D. TUBE	PIPE THREAD SIZE
P-72A-4A	1/4 in	1/8 in
P-72A-4B	1/4 in	1/4 in
P-72A-5A	5/16 in	1/8 in
P-72A-5B	5/16 in	1/4 in
P-72A-6A	3/8 in	1/8 in
P-72A-6B	3/8 in	1/4 in
P-72A-6C	3/8 in	3/8 in
P-72A-8C	1/2 in	3/8 in
P-72A-8D	1/2 in	1/2 in
P-72A-10D	5/8 in	1/2 in
P-72A-12D	3/4 in	1/2 in
P-72A-12E	3/4 in	3/4 in

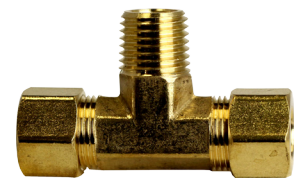

FOR REFERENCE ONLY -
SAE 060425BA

P-76A STREET TEE, FPT TO MPT TO TUBE

PART NUMBER	O.D. TUBE	PIPE THREAD SIZE
P-76A-4A	1/4 in	1/8 in
P-76A-4B	1/4 in	1/4 in
P-76A-6B	3/8 in	1/4 in

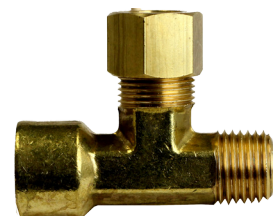



Compression

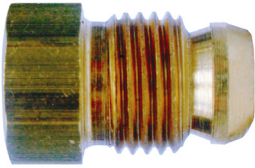

P-81LB CONTROL NUT

PART NUMBER	O.D. TUBE
P-81LB-4	1/4 in



P-N5CT COMPRESSION CAP

PART NUMBER	SIZE
P-N5CT-4	1/4 in
P-N5CT-6	3/8 in
P-N5CT-8	1/2 in
P-N5CT-10	5/8 in

A-Lign Compression

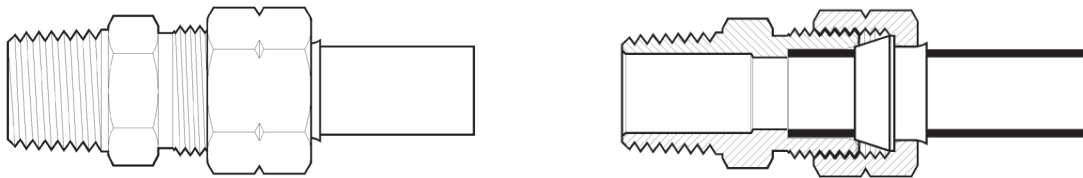

Tube O.D.	1/8	3/16	1/4	5/16	3/8	7/16	1/2	5/8	3/4	1
Thread	5/16-24	3/8-24	7/16-24	1/2-24	9/16-24	5/8-24	11/16-20	13/16-18	1-18	1-1/8-18

MATERIALS:

CA360, CA345, CA377

VIBRATION RESISTANCE:

Fair

WORKING PRESSURE:

400 PSI Maximum based on tubing size.
ALWAYS consult tubing specifications.

TEMPERATURE RANGE:

-65 to +212°F
-54 to +100°C

CONFORMANCE:

Meets functional requirements of SAE as indicated by configuration.

APPLICATIONS:

Air, oil, water, lubricant and other applications which use brass, copper, aluminum and thermoplastic tubing. Use of thermoplastic tubing requires a brass insert. (Fitting Configuration P-60AE)

HOW TO ORDER:

- Compression fittings may be converted to A-Lign style by ordering the standard fitting assembly and A-Lign nut separately.
- You then have the option of using the fitting conventionally or converting to the A-Lign style.
- We no longer offer assembly of A-Ligns.

BENEFIT:

- Reduces maintenance costs and assembly time.
- Lower costs based on fewer vendors.
- Reduces the number of SKU's required to cover need.

FEATURE:

- Sleeve is integrated with nut.
- Wide range of sizes and styles.
- Standard compression bodies.

ADVANTAGE:

- Faster, more reliable assembly.
- One-stop shop for all needs.
- Interchangeable between part families.

ASSEMBLY INSTRUCTIONS:

- Cut tubing squarely and remove burrs.
- Slide nut and sleeve on tubing, threaded end out.
- Insert the tube into fitting until it bottoms.
- Lubricate threads.
- Assemble nut to body finger tight.
- Tighten with a wrench as follows:
1/8" to 5/16" 1-1/4 Additional Turns
3/8" to 7/8" 2-1/4 Additional Turns

DO NOT OVER TIGHTEN OR TUBING MAY SPLIT



A-Lign Compression

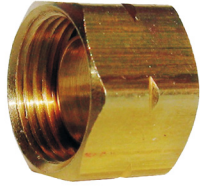

P-961A NUT WITH CAPTIVE SLEEVE

PART NUMBER	O.D. TUBE
P-961A-2	1/8 in
P-961A-3	3/16 in
P-961A-4	1/4 in
P-961A-5	5/16 in
P-961A-6	3/8 in
P-961A-8	1/2 in
P-961A-10	5/8 in
P-961A-12	3/4 in

D.O.T. Nylon Tube Air Brake Fittings

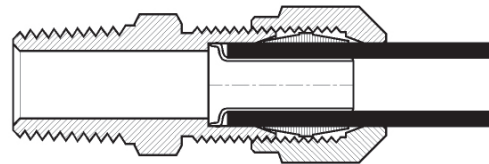
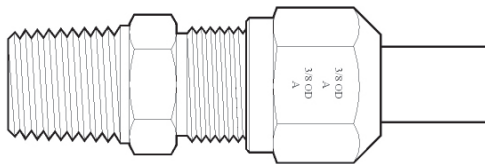

Tube O.D.	1/4	3/8	1/2	5/8	3/4
Thread Size	7/16-24	17/32-24	11/16-20	13/16-18	1-18

MATERIALS:

CA360, CA345, C377

VIBRATION RESISTANCE:

Excellent

WORKING PRESSURE:

150 PSI Maximum based on tubing size.
ALWAYS consult tubing specifications.

TEMPERATURE RANGE:

-40 to +200°F
-40 to +93°C

CONFORMANCE:

Meets requirements of SAE and DOT as indicated by configuration.

APPLICATIONS:

Air brake systems on heavy trucks and trailers that are plumbed with nylon tubing.

HOW TO ORDER:

- Supplied as three piece assemblies including body (with staked tube support), nut and sleeve.
- For body only, use "B" prefix.
- For pipe sealant (Loctite 516), add "VS" prefix.
- Some items available on Special Order basis only.

NOMENCLATURE:

PVS68NAB-6B

- 68NAB: Fitting Configuration
- 6: Tube Size in sixteenths ($6/16 = 3/8$)
- B: Pipe Size 1/4"

Dimensions subject to change without notice

BENEFIT:

- Reduces maintenance costs and assembly time.
- Lower costs based on fewer vendors.
- Assures safe, reliable nylon air brake tube assemblies.

FEATURE:

- No special tube prep required.
- Wide range of sizes and styles.
- Ribbed sleeve.

ADVANTAGE:

- Faster, more reliable assembly.
- One-stop shop for all needs.
- Designed especially for copper tubing.

ASSEMBLY INSTRUCTIONS:

- Cut tubing squarely and remove burrs.
- Slide tubing into the preassembled fitting until the tube bottoms.
- Tighten with a wrench as follows:
1/4" - 3/8": 1 3/4 Additional Turns
1/2" - 3/4": 3 1/4 Additional Turns

DO NOT OVER TIGHTEN OR TUBING MAY SPLIT



D.O.T. Nylon Tube Air Brake Fittings



P-59A INSERT

PART NUMBER	O.D. TUBE
P-59A-4	1/8 in
P-59A-6	3/8 in
P-59A-8	1/2 in



FOR REFERENCE ONLY -
SAE 100115BA

P-60NAB SLEEVE

PART NUMBER	O.D. TUBE
P-60NAB-4	1/4 in
P-60NAB-6	3/8 in
P-60NAB-8	1/2 in



FOR REFERENCE ONLY -
SAE 100110BA

P-61NAB NUT

PART NUMBER	O.D. TUBE
P-61NAB-4	1/4 in
P-61NAB-6	3/8 in
P-61NAB-8	1/2 in

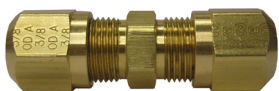

FOR REFERENCE ONLY -
SAE 100101BA

P-62NAB UNION, TUBE BOTH ENDS

PART NUMBER	O.D. TUBE
P-62NAB-4	1/4 in
P-62NAB-6	3/8 in
P-62NAB-8	1/2 in



FOR REFERENCE ONLY -
SAE 100401BA

P-64NAB TEE, TUBE ALL ENDS

PART NUMBER	O.D. TUBE
P-64NAB-4	1/4 in
P-64NAB-6	3/8 in
P-64NAB-8	1/2 in

D.O.T. Nylon Tube Air Brake Fittings

P-65NAB ELBOW, TUBE BOTH ENDS

PART NUMBER	O.D. TUBE
P-65NAB-4	1/4 in
P-65NAB-6	3/8 in
P-65NAB-8	1/2 in



FOR REFERENCE ONLY -
SAE 100201BA

P-66NAB ADAPTER, TUBE TO FPT

PART NUMBER	O.D. TUBE	PIPE THREAD SIZE
P-66NAB-4A	1/4 in	1/8 in
P-66NAB-4B	1/4 in	1/4 in
P-66NAB-6A	3/8 in	1/8 in
P-66NAB-6B	3/8 in	1/4 in
P-66NAB-6C	3/8 in	3/8 in
P-66NAB-8C	1/2 in	3/8 in
P-66NAB-8D	1/2 in	1/2 in



FOR REFERENCE ONLY -
SAE 100103BA

P-VS68NAB CONNECTOR, TUBE TO MPT

PART NUMBER	O.D. TUBE	PIPE THREAD SIZE
PVS68NAB-4A	1/4 in	1/8 in
PVS68NAB-4B	1/4 in	1/4 in
PVS68NAB-4C	1/4 in	3/8 in
PVS68NAB-6A	3/8 in	1/8 in
PVS68NAB-6B	3/8 in	1/4 in
PVS68NAB-6C	3/8 in	3/8 in
PVS68NAB-6D	3/8 in	1/2 in
PVS68NAB-8B	1/2 in	1/4 in
PVS68NAB-8C	1/2 in	3/8 in
PVS68NAB-8D	1/2 in	1/2 in



FOR REFERENCE ONLY -
SAE 100102BA

P-VS69NAB ELBOW, 90° TUBE TO MPT

PART NUMBER	O.D. TUBE	PIPE THREAD SIZE
PVS69NAB-4A	1/4 in	1/8 in
PVS69NAB-4B	1/4 in	1/4 in
PVS69NAB-4C	1/4 in	3/8 in
PVS69NAB-6A	3/8 in	1/8 in
PVS69NAB-6B	3/8 in	1/4 in
PVS69NAB-6C	3/8 in	3/8 in
PVS69NAB-6D	3/8 in	1/2 in
PVS69NAB-8B	1/2 in	1/4 in
PVS69NAB-8C	1/2 in	3/8 in
PVS69NAB-8D	1/2 in	1/2 in



FOR REFERENCE ONLY -
SAE 100202BA



D.O.T. Nylon Tube Air Brake Fittings



FOR REFERENCE ONLY -
SAE 010203BA

P-70NAB ELBOW, 90° TUBE TO FPT

PART NUMBER	O.D. TUBE	PIPE THREAD SIZE
P-70NAB-4A	1/4 in	1/8 in
P-70NAB-6A	3/8 in	1/8 in
P-70NAB-6B	3/8 in	1/4 in
P-70NAB-6C	3/8 in	3/8 in
P-70NAB-8C	1/2 in	3/8 in
P-70NAB-8D	1/2 in	1/2 in

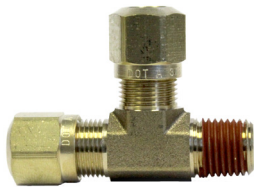

FOR REFERENCE ONLY -
SAE 0100424BA

P-VS71NAB MALE RUN TEE, TUBE TO MPT TO TUBE

PART NUMBER	O.D. TUBE	PIPE THREAD SIZE
PVS71NAB-4A	1/4 in	1/8 in
PVS71NAB-4B	1/4 in	1/4 in
PVS71NAB-6B	3/8 in	1/4 in
PVS71NAB-6C	3/8 in	3/8 in
PVS71NAB-8C	1/2 in	3/8 in
PVS71NAB-8D	1/2 in	1/2 in



FOR REFERENCE ONLY -
SAE 0100425BA

P-VS72NAB MALE BRANCH TEE, TUBE TO MPT TO MPT

PART NUMBER	O.D. TUBE	PIPE THREAD SIZE
PVS72NAB-4A	1/4 in	1/8 in
PVS72NAB-4B	1/4 in	1/4 in
PVS72NAB-6A	3/8 in	1/8 in
PVS72NAB-6B	3/8 in	1/4 in
PVS72NAB-6C	3/8 in	3/8 in
PVS72NAB-8C	1/2 in	3/8 in
PVS72NAB-8D	1/2 in	1/2 in



P-VS79NAB ELBOW, 45° TUBE TO MPT

PART NUMBER	O.D. TUBE	PIPE THREAD SIZE
PVS79NAB-4A	1/4 in	1/8 in
PVS79NAB-4B	1/4 in	1/4 in
PVS79NAB-6A	3/8 in	1/8 in
PVS79NAB-6B	3/8 in	1/4 in
PVS79NAB-6C	3/8 in	3/8 in
PVS79NAB-6D	3/8 in	1/2 in
PVS79NAB-8B	1/2 in	1/4 in
PVS79NAB-8C	1/2 in	3/8 in
PVS79NAB-8D	1/2 in	1/2 in

Garden Hose

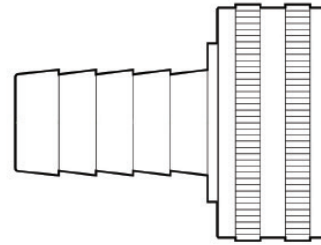
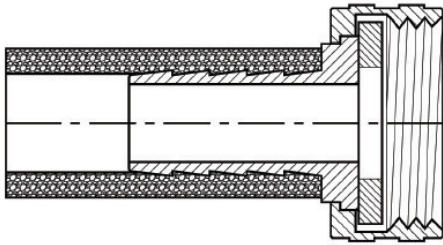

MATERIALS:

CA360, CA345, CA377

VIBRATION RESISTANCE:

Good

WORKING PRESSURE:

150 PSI Maximum based on hose size.
ALWAYS consult hose specifications

TEMPERATURE RANGE:

35 to +100°F
2 to +38°C

CONFORMANCE:

ALWAYS consult hose and/or tubing specifications for media compatibility, pressure and temperature ratings.

APPLICATIONS:

Garden hose applications which do not exceed 150 PSI including water, irrigation, car wash and piping systems.

HOW TO ORDER:

- Order as complete assemblies or individual components by part number.
- Some items available on Special Order basis only.

NOMENCLATURE:

P-19A-12D

- 19A: Fitting Configuration
- 12: Hose Size in sixteenths ($12/16 = 3/4$)
- D: Pipe Size 1/2"

Dimensions subject to change without notice.

BENEFIT:

- No equipment investment required.
- Reduces the number of SKU's required to cover needs.

FEATURE:

- Field attachable hose ends.
- Attach with clamps or ferrules.

ADVANTAGE:

- No assembly equipment required.
- Applicable in wider range of applications.
- Conforms to more customers' requirements.

ASSEMBLY INSTRUCTIONS:

- Cut hose squarely and remove burrs.
- Slide ferrule or hose clamp onto hose.
- Insert hose barb into hose until hose bottoms against fitting hex.
- Tighten clamp or crimp ferrule per manufacturer's specifications.
- Install rubber washer in all female hose ends.



Garden Hose

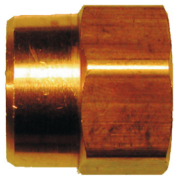

P-5A FEMALE HOSE TO FEMALE PIPE

PART NUMBER	HOSE THREAD	PIPE THREAD SIZE
P-5A-12D	3/4 in	1/2 in
P-5A-12E	3/4 in	3/4 in

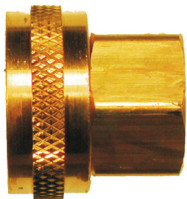

P-5AS FEMALE HOSE TO FEMALE PIPE, SWIVEL

PART NUMBER	HOSE THREAD	PIPE THREAD SIZE
P-5AS-12D	3/4 in	1/2 in
P-5AS-12E	3/4 in	3/4 in



P-18A MALE HOSE TO FEMALE PIPE

PART NUMBER	HOSE THREAD	PIPE THREAD SIZE
P-18A-12B	3/4 in	1/4 in
P-18A-12C	3/4 in	3/8 in
P-18A-12D	3/4 in	1/2 in
P-18A-12E	3/4 in	3/4 in

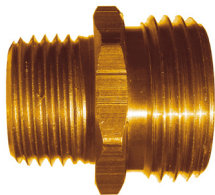

P-19A MALE HOSE TO MALE PIPE

PART NUMBER	HOSE THREAD	PIPE THREAD SIZE
P-19A-12C	3/4 in	3/8 in
P-19A-12D	3/4 in	1/2 in
P-19AF-12DE*	3/4 in	3/4 in

*TAPPED 1/2 FPT

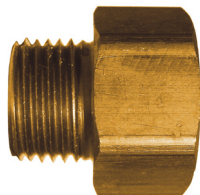

P-20A FEMALE HOSE TO MALE PIPE

PART NUMBER	HOSE THREAD	PIPE THREAD SIZE
P-20A-12D	3/4 in	1/2 in
P-20A-12E	3/4 in	3/4 in

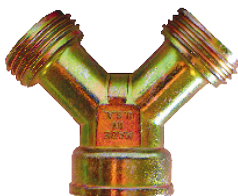

P-21A HOSE "Y"

PART NUMBER	HOSE THREAD
P-21A-12	3/4 in

Garden Hose

P-22A FEMALE HOSE TO FEMALE HOSE

PART NUMBER	HOSE THREAD
P-22A-12	3/4 in x 3/4 in

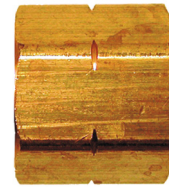

P-22AS FEMALE HOSE TO FEMALE HOSE, SWIVEL

PART NUMBER	HOSE THREAD
P-22AS-12E	3/4 in x 3/4 in

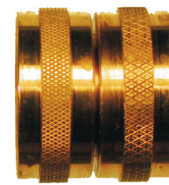

P-23A MALE HOSE TO MALE HOSE

PART NUMBER	HOSE THREAD
P-23A-12	3/4 in x 3/4 in

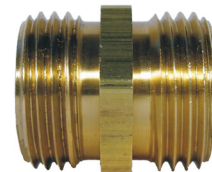

P-120EC EVAPORATIVE COOLER

PART NUMBER	MALE PIPE THREAD	FEMALE PIPE THREAD
P-120EC-DD	1/2 in	1/2 in
P-120EC-EE	3/4 in	3/4 in

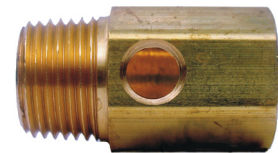

P-201GH HOSE BARB TO MALE GARDEN HOSE

PART NUMBER	GARDEN HOSE THREAD	HOSE I.D.	LENGTH
STANDARD			
P-201GH-8E	3/4 in	1/2 in	1.56 in
P-201GH-10E	3/4 in	5/8 in	1.56 in
P-201GH-12E	3/4 in	3/4 in	1.56 in
LONG			
P-201GH-8EX	3/4 in	1/2 in	1.93 in
P-201GH-10EX	3/4 in	5/8 in	1.93 in
P-201GH-12EX	3/4 in	3/4 in	1.93 in

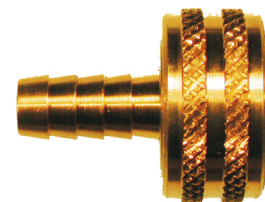



Garden Hose



P-202GHS HOSE BARB TO HOSE BARB, SWIVEL

PART NUMBER	HOSE I.D.	LENGTH
STANDARD		
P-202GHS-88	1/2 in	3.00 in
P-202GHS-1010	5/8 in	3.00 in
P-202GHS-1212	3/4 in	3.00 in
LONG		
P-202GHS-8X	1/2 in	3.48 in
P-202GHS-10X	5/8 in	3.48 in
P-202GHS-12X	3/4 in	3.48 in

GARDEN HOSE ASSEMBLIES AVAILABLE WITH HEX NUTS EXTRA LONG LENGTHS AVAILABLE BY SPECIAL ORDER.



P-209GHS HOSE BARB TO FEMALE GARDEN HOSE, SWIVEL

PART NUMBER	GARDEN HOSE THREAD	HOSE I.D.	LENGTH
STANDARD			
P-209GHS-8E	3/4 in	1/2 in	1.52 in
P-209GHS-10E	3/4 in	5/8 in	1.52 in
P-209GHS-12E	3/4 in	3/4 in	1.52 in
LONG			
P-209GHS-8EX	3/4 in	1/2 in	1.87 in
P-209GHS-10EX	3/4 in	5/8 in	1.87 in
P-209GHS-12EX	3/4 in	3/4 in	1.87 in

GARDEN HOSE ASSEMBLIES AVAILABLE WITH HEX NUTS EXTRA LONG LENGTHS AVAILABLE BY SPECIAL ORDER.



P-ECD-D PANEL MOUNT DRAIN COOLER

PART NUMBER	PIPE THREAD
P-ECD-D	1/2 FPT



P-GH-W GARDEN HOSE WASHER

PART NUMBER	GARDEN HOSE THREAD
P-GH-W	3/4 in

Garden Hose

P-GHN1 GARDEN HOSE NUT

PART NUMBER	HOSE THREAD	TYPE
P-GHN1	3/4 in	Round
P-GHN1H	3/4 in	HEX

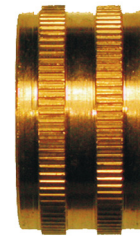

P-GHN5 GARDEN HOSE CAP

PART NUMBER	HOSE THREAD	PIPE THREAD	TYPE
P-GHN5	3/4 in	N/A	Round
P-GHN5-TA	3/4 in	1/8 in	Round
P-GHN5H	3/4 in	N/A	HEX

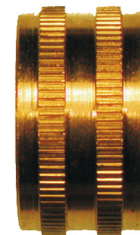

P-W1 WATER INLET ASSEMBLY, GH SWIVEL TO MPT

PART NUMBER	HOSE THREAD	PIPE THREAD
P-W1-B	3/4 in	1/4 in
P-W1-C	3/4 in	3/8 in

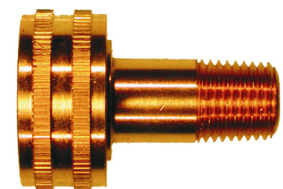

P-W1 WATER INLET ASSEMBLY, GH SWIVEL TO FLARE

PART NUMBER	HOSE THREAD	FLARE THREAD
P-W1-6	3/4 in	3/8 in
P-W1-8	3/4 in	1/2 in





Hose Barb

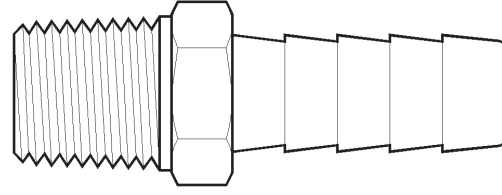
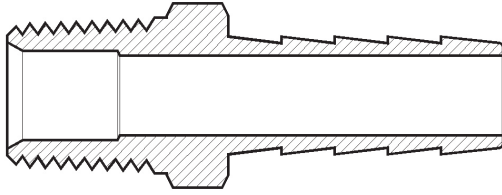

MATERIALS:

CA360, CA345, CA377

VIBRATION RESISTANCE:

Excellent

WORKING PRESSURE:

150 PSI Maximum based on hose/tubing size.
ALWAYS consult hose/tubing specifications.

TEMPERATURE RANGE:

-40 to +160°F
-40 to +71°C

CONFORMANCE:

ALWAYS consult hose and/or tubing specifications for media compatibility, pressure and temperature ratings.

APPLICATIONS:

Air, water and other low pressure fluids conveyed via low pressure hose or thermoplastic tubing.

HOW TO ORDER:

- Order as complete assemblies or individual components by part number.
- Some items available on Special Order basis only.

NOMENCLATURE:

P-209A-3A

- 209A: Fitting Configuration
- 3: Hose Size in sixteenths ($3/16 = 3/16$)
- A: Pipe Size $1/8''$

Dimensions subject to change without notice

BENEFIT:

- No equipment investment required.
- Reduces the number of SKU's required to cover needs.

FEATURE:

- Field attachable hose ends.
- Attach with clamps or ferrules.

ADVANTAGE:

- No assembly equipment required.
- Applicable in wider range of applications.

ASSEMBLY INSTRUCTIONS:

- Cut hose squarely and remove burrs.
- Slide ferrule or hose clamp onto hose.
- Lubricate hose, then insert hose barb into hose until hose bottoms against fitting hex.
- Tighten clamp or crimp ferrule per manufacturer's specifications.

Hose Barb

P-201A HOSE BARB TO MPT

PART NUMBER	HOSE I.D.	PIPE THREAD SIZE
P-201A-2A	1/8 in	1/8 in
P-201A-3A	3/16 in	1/8 in
P-201A-3B	3/16 in	1/4 in
P-201A-4A	1/4 in	1/8 in
P-201A-4B	1/4 in	1/4 in
P-201A-4C	1/4 in	3/8 in
P-201A-4D	1/4 in	1/2 in
P-201A-5A	5/16 in	1/8 in
P-201A-5B	5/16 in	1/4 in
P-201A-5C	5/16 in	3/8 in
P-201A-6A	3/8 in	1/8 in
P-201A-6B	3/8 in	1/4 in
P-201A-6C	3/8 in	3/8 in
P-201A-6D	3/8 in	1/2 in
P-201A-6E	3/8 in	3/4 in
P-201A-8B	1/2 in	1/4 in
P-201A-8C	1/2 in	3/8 in
P-201A-8D	1/2 in	1/2 in
P-201A-8E	1/2 in	3/4 in
P-201A-10C	5/8 in	3/8 in
P-201A-10D	5/8 in	1/2 in
P-201A-10E	5/8 in	3/4 in
P-201A-12D	3/4 in	1/2 in
P-201A-12E	3/4 in	3/4 in
P-201A-16E	1 in	3/4 in
P-201A-16F	1 in	1 in

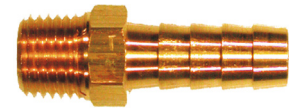

P-201BF HOSE TO MALE FLARE

PART NUMBER	HOSE I.D.	MALE FLARE
P-201BF-44	1/4 in	1/4 in
P-201BF-46	1/4 in	3/8 in
P-201BF-66	3/8 in	3/8 in
P-201BF-68	3/8 in	1/2 in
P-201BF-88	1/2 in	1/2 in

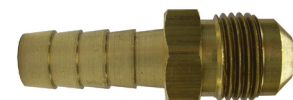



Hose Barb

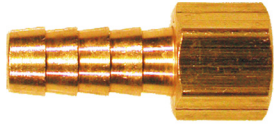

P-209A HOSE BARB TO FPT

PART NUMBER	HOSE I.D.	PIPE THREAD SIZE
P-209A-2A	1/8 in	1/8 in
P-209A-3A	3/16 in	1/8 in
P-209A-3B	3/16 in	1/4 in
P-209A-4A	1/4 in	1/8 in
P-209A-4B	1/4 in	1/4 in
P-209A-4C	1/4 in	3/8 in
P-209A-5A	5/16 in	1/8 in
P-209A-5B	5/16 in	1/4 in
P-209A-5C	5/16 in	3/8 in
P-209A-6A	3/8 in	1/8 in
P-209A-6B	3/8 in	1/4 in
P-209A-6C	3/8 in	3/8 in
P-209A-6D	3/8 in	1/2 in
P-209A-8B	1/2 in	1/4 in
P-209A-8C	1/2 in	3/8 in
P-209A-8D	1/2 in	1/2 in

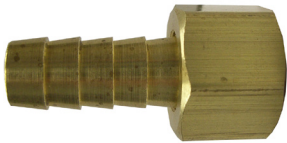

P-209AS HOSE BARB TO SWIVEL BALL END (FEMALE STRAIGHT MECHANICAL)

PART NUMBER	HOSE I.D.	PIPE THREAD SIZE
P-209AS-4B	1/4 in	1/4 in
P-209AS-6B	3/8 in	1/4 in
P-209AS-6C	3/8 in	3/8 in
P-209AS-8C	1/2 in	3/8 in
P-209AS-8D	1/2 in	1/2 in
P-209AS-12E	3/4 in	3/4 in

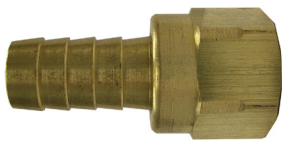

P-209ASF HOSE BARB TO FEMALE FLARE SWIVEL

PART NUMBER	HOSE I.D.	FEMALE FLARE
P-209ASF-44	1/4 in	1/4 in
P-209ASF-46	1/4 in	3/8 in
P-209ASF-66	3/8 in	3/8 in
P-209ASF-68	3/8 in	1/2 in
P-209ASF-88	1/2 in	1/2 in

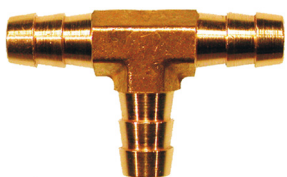

P-HBT2 HOSE BARB TEE

PART NUMBER	HOSE I.D.
P-HBT2-4	1/4 in
P-HBT2-5	5/16 in
P-HBT2-6	3/8 in

Hose Barb

P-HE1 ELBOW, 90° HOSE TO MPT

PART NUMBER	HOSE I.D.	PIPE THREAD SIZE
P-HE1-4A	1/4 in	1/8 in
P-HE1-4B	1/4 in	1/4 in
P-HE1-4C	1/4 in	3/8 in
P-HE1-5A	5/16 in	1/8 in
P-HE1-5B	5/16 in	1/4 in
P-HE1-5C	5/16 in	3/8 in
P-HE1-6A	3/8 in	1/8 in
P-HE1-6B	3/8 in	1/4 in
P-HE1-6C	3/8 in	3/8 in
P-HE1-6D	3/8 in	1/2 in
P-HE1-8B	1/2 in	1/4 in
P-HE1-8C	1/2 in	3/8 in
P-HE1-8D	1/2 in	1/2 in
P-HE1-10C	5/8 in	3/8 in
P-HE1-10D	5/8 in	1/2 in

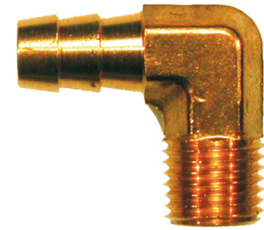

P-HE1-45 ELBOW, 45° HOSE TO MPT

PART NUMBER	HOSE I.D.	PIPE THREAD SIZE
P-HE1-45-4A	1/4 in	1/8 in
P-HE1-45-5A	5/16 in	1/8 in
P-HE1-45-5B	5/16 in	1/4 in
P-HE1-45-6A	3/8 in	1/8 in
P-HE1-45-6B	3/8 in	1/4 in
P-HE1-45-6C	3/8 in	3/8 in
P-HE1-45-8B	1/2 in	1/4 in
P-HE1-45-8C	1/2 in	3/8 in
P-HE1-45-10C	5/8 in	3/8 in

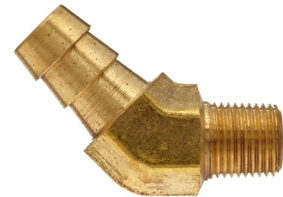

P-HM HOSE MENDER, HOSE TO HOSE

PART NUMBER	HOSE I.D.
P-HM-2	1/8 in
P-HM-3	3/16 in
P-HM-4	1/4 in
P-HM-5	5/16 in
P-HM-6	3/8 in
P-HM-8	1/2 in
P-HM-10	5/8 in
P-HM-12	3/4 in





Grip-On Hose Barb

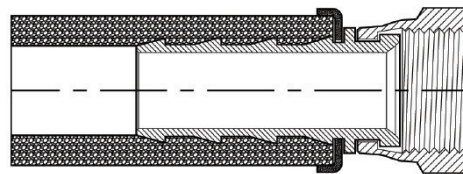
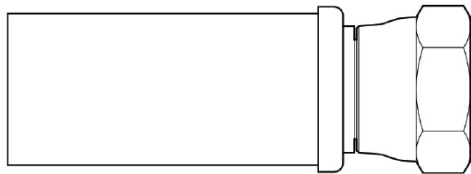

MATERIALS:

CA360, CA345
Hose protection cap is thermoplastic.

VIBRATION RESISTANCE:

Excellent

WORKING PRESSURE:

300 PSI Maximum based on hose size.
ALWAYS consult hose specifications.

TEMPERATURE RANGE:

-40 to +212°F
-40 to +100°C

CONFORMANCE:

ALWAYS consult hose and/or tubing specifications for media compatibility, pressure and temperature ratings.

APPLICATIONS:

Use with rubber or thermoplastic push-on style hose. Common in low pressure air and water applications including shop air lines, pneumatic tools, gasoline lines and diesel lines.

HOW TO ORDER:

- Order as complete assemblies or individual components by part number.
- Some items available on Special Order basis only.

NOMENCLATURE:

P-308-66

- 308: Fitting Configuration
- 6: Hose Size in sixteenths ($6/16 = 3/8$)
- 6: Tube Size in sixteenths ($6/16 = 3/8$)

Dimensions subject to change without notice

BENEFIT:

- No equipment investment required.
- Reduces assembly cost and increases consistency.

FEATURE:

- Field attachable hose ends.
- No clamps or ferrules required.

ADVANTAGE:

- No assembly equipment required.
- Speeds up assembly time and reliability.

ASSEMBLY INSTRUCTIONS:

- Cut hose squarely and remove burrs.
- Push hose onto barb until hose bottoms against plastic ring.

Grip-On Hose Barb

P-301 HOSE TO MPT

PART NUMBER	HOSE I.D.	PIPE THREAD SIZE
P-301-42	1/4 in	1/8 in
P-301-44	1/4 in	1/4 in
P-301-46	1/4 in	3/8 in
P-301-52	5/16 in	1/8 in
P-301-62	3/8 in	1/8 in
P-301-64	3/8 in	1/4 in
P-301-66	3/8 in	3/8 in
P-301-68	3/8 in	1/2 in
P-301-84	1/2 in	1/4 in
P-301-86	1/2 in	3/8 in
P-301-88	1/2 in	1/2 in
P-301-812	1/2 in	3/4 in
P-301-108	5/8 in	1/2 in
P-301-1212	3/4 in	3/4 in

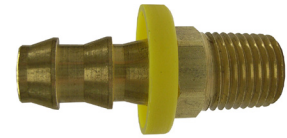

P-302 HOSE TO 45° SAE MALE

PART NUMBER	HOSE I.D.	FLARE THREAD
P-302-44	1/4 in	1/4 in
P-302-45	1/4 in	5/16 in
P-302-66	3/8 in	3/8 in
P-302-68	1/2 in	1/2 in

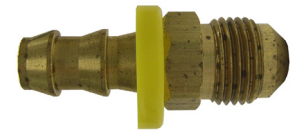

P-303 RIGID TUBE SHANK

PART NUMBER	HOSE I.D.	TUBE I.D.
P-303-43	1/4 in	3/16 in
P-303-44	1/4 in	1/4 in
P-303-45	1/4 in	5/16 in
P-303-66	3/8 in	3/8 in
P-303-88	1/2 in	1/2 in
P-303-1010	5/8 in	5/8 in



P-304 HOSE SPLICER

PART NUMBER	HOSE I.D.
P-304-44	1/4 in
P-304-55	5/16 in
P-304-66	3/8 in
P-304-88	1/2 in
P-304-1010	5/8 in
P-304-1212	3/4 in





Grip-On Hose Barb

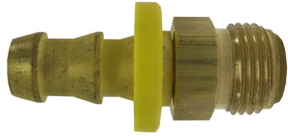

P-305 HOSE TO INVERTED FLARE, SWIVEL

PART NUMBER	HOSE I.D.	INVERTED FLARE THREAD
P-305-43	1/4 in	3/16 in
P-305-44	1/4 in	1/4 in
P-305-55	5/16 in	5/16 in
P-305-66	3/8 in	3/8 in
P-305-88	1/2 in	1/2 in
P-305-1010	5/8 in	5/8 in

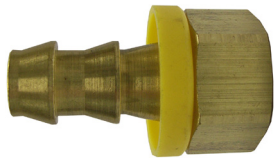

P-306 HOSE TO INVERTED FLARE

PART NUMBER	HOSE I.D.	INVERTED FLARE THREAD
P-306-43	1/4 in	3/16 in
P-306-44	1/4 in	1/4 in
P-306-45	1/4 in	5/16 in
P-306-66	3/8 in	3/8 in
P-306-88	1/2 in	1/2 in

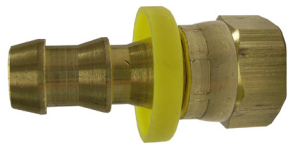

P-307 HOSE TO FEMALE 45° FLARE, SWIVEL

PART NUMBER	HOSE I.D.	FLARE THREAD
P-307-46	1/4 in	3/8 in
P-307-66	3/8 in	3/8 in
P-307-1212	3/4 in	3/4 in



P-308 HOSE TO FEMALE JIC 37° FLARE, SWIVEL

PART NUMBER	HOSE I.D.	37° FLARE THREAD
P-308-66	3/8 in	3/8 in
P-308-88	1/2 in	1/2 in
P-308-1212	3/4 in	3/4 in

Grip-On Hose Barb

P-309 HOSE TO DUAL ANGLE, SWIVEL, 45°/37°

PART NUMBER	HOSE I.D.	FLARE THREAD
P-309-44	1/4 in	1/4 in
P-309-45	1/4 in	5/16 in
P-309-55	5/16 in	5/16 in
P-309-68	3/8 in	1/2 in
P-309-88	1/2 in	1/2 in
P-309-1010	5/8 in	5/8 in

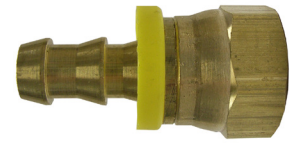

P-3099 HOSE TO FPT

PART NUMBER	HOSE I.D.	PIPE THREAD SIZE
P-3099-42	1/4 in	1/8 in
P-3099-44	1/4 in	1/4 in
P-3099-64	3/8 in	1/4 in
P-3099-66	3/8 in	3/8 in
P-3099-86	1/2 in	3/8 in
P-3099-88	1/2 in	1/2 in



P-310 HOSE TO JIC MALE 37°

PART NUMBER	HOSE I.D.	37° FLARE THREAD
P-310-44	1/4 in	1/4 in
P-310-45	1/4 in	5/16 in
P-310-66	3/8 in	3/8 in

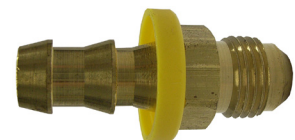



POL

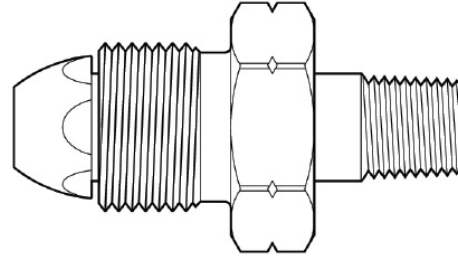
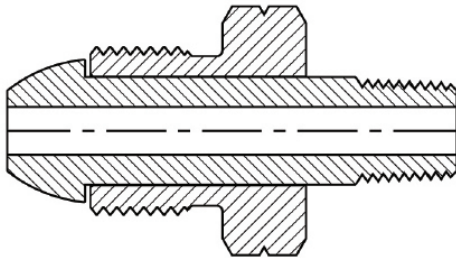

MATERIALS:

CA360, CA345, CA377

VIBRATION RESISTANCE:

Good

WORKING PRESSURE:

250 PSI Maximum based on hose/tubing size.
ALWAYS consult hose/tubing specifications.

TEMPERATURE RANGE:

-65 to +200°F
-54 to +93°C

CONFORMANCE:

ALWAYS consult hose and/or tubing specifications for media compatibility, pressure and temperature ratings.

APPLICATIONS:

LP Gas assemblies.

HOW TO ORDER:

- Order as complete assemblies or individual components by part number.
- Some items available on Special Order basis only.

NOMENCLATURE:

P-POL-U2-6

- POL-U2: Fitting Configuration
- 6: Tube Size in sixteenths ($6/16 = 3/8$)

Dimensions subject to change without notice

BENEFIT:

- More sales opportunities based on availability.

FEATURE:

- Designed for LP Gas applications.

ADVANTAGE:

- Fits unique LP Gas connectors.

POL

P-POL-LN NUT, 1-1/8" HEX

PART NUMBER	EXTERNAL THREAD
P-POL-LN	0.880 - 14 LH



P-POL-N NUT, 7/8" HEX

PART NUMBER	EXTERNAL THREAD
P-POL-N	0.880 - 14 LH

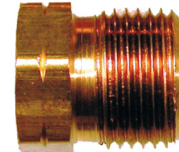

P-POL-LTPH ADAPTER, 2-9/16"

PART NUMBER	PIPE THREAD
P-POL-LTPH	1/4 in



P-POL-N5 CAP

PART NUMBER	INTERNAL THREAD
P-POL-N5	0.880 - 14 LH

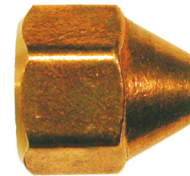

P-POL-P2 PLUG

PART NUMBER	EXTERNAL THREAD
P-POL-P2	0.880 - 14 LH

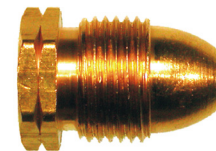

P-POL-U2 POL TO SAE FLARE

PART NUMBER	O.D. FLARE	EXTERNAL THREAD
P-POL-U2-6	3/8 in	0.880 - 14 LH
P-POL-U2-8	1/2 in	0.880 - 14 LH
P-POL-U2-10	5/8 in	0.880 - 14 LH

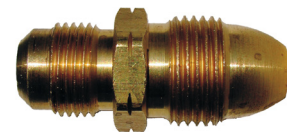

P-POL-U3 POL TO FPT

PART NUMBER	EXTERNAL THREAD	PIPE THREAD SIZE
P-POL-U3B	0.880-14 LH	1/4 FPT





Needle Valves

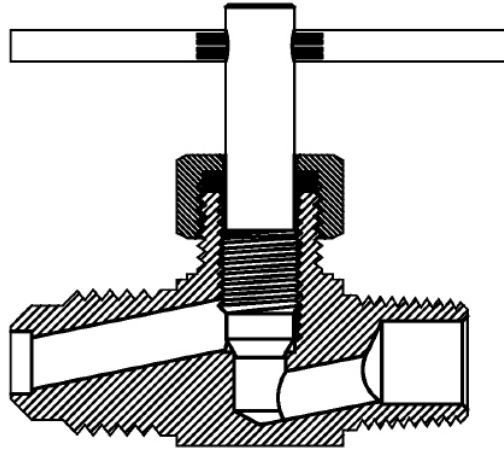

MATERIALS:

CA377

WORKING PRESSURE:

150 PSI Maximum based on tube size.
ALWAYS consult tubing specifications.

TEMPERATURE RANGE:

-65 to +250°F
-54 to +121°C

CONFORMANCE:

ALWAYS consult hose and/or tubing specifications for media compatibility, pressure and temperature ratings.

APPLICATIONS:

Used in low pressure pneumatic instrumentation and hydraulic systems that are plumbed with copper, thermoplastic, steel and aluminum tubing.

HOW TO ORDER:

- Order by part number.
- Compression valves are supplied with nuts, and sleeves.

- For A-Lign nut, add "9" prefix.
- Some items available on Special Order basis only.

BENEFIT:

- Reduces leakage improving system reliability.
- Enables customer to adjust flow capacity as needed.
- Reduces maintenance costs and unsightly leaks.

FEATURE:

- Metal to metal seat.
- Easily adjusts.

ADVANTAGE:

- Positive seal.
- Allows for flow control.
- Fewer leaks in the system.

ASSEMBLY INSTRUCTIONS:

- Always install with pressure against seat.
- NEVER direct pressure against stem threads.

Needle Valves

NEEDLE VALVE FPT TO FPT

PART NUMBER	PIPE THREAD SIZE
P-31NV	1/8 in x 1/8 in
P-32NV	1/4 in x 1/4 in

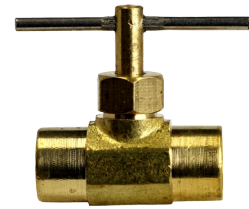

NEEDLE VALVE FPT TO MPT

PART NUMBER	PIPE THREAD SIZE
P-48NV	1/8 in x 1/8 in
P-49NV	1/4 in x 1/4 in

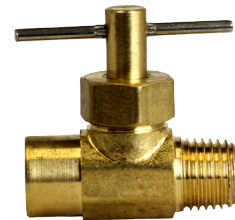

NEEDLE VALVE COMPRESSION TO MPT

PART NUMBER	O.D. TUBE	PIPE THREAD SIZE
P-101CP	1/4 in	1/8 in
P-101CP-4	1/4 in	1/4 in
P-102CP	5/16 in	1/8 in
P-143CP	3/8 in	1/4 in

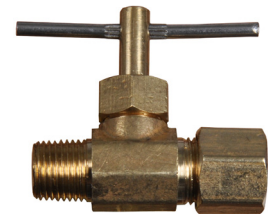

NEEDLE VALVE COMPRESSION TO MPT, ANGLE

PART NUMBER	O.D. TUBE	PIPE THREAD SIZE
P-103CC	1/4 in	1/8 in
P-103-4CC	1/4 in	1/4 in
P-203CC	5/16 in	1/8 in
P-303ACC	3/8 in	1/8 in
P-303CC	3/8 in	1/4 in

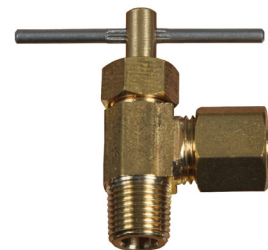

NEEDLE VALVE FLARE TO MPT, ANGLE

PART NUMBER	O.D. TUBE	PIPE THREAD SIZE
P-103SAE	1/4 in	1/8 in
P-303SAE	3/8 in	1/4 in



NEEDLE VALVE FLARE TO MPT

PART NUMBER	O.D. TUBE	PIPE THREAD SIZE
P-104SAE	1/4 in	1/8 in
P-108SAE	3/8 in	1/4 in

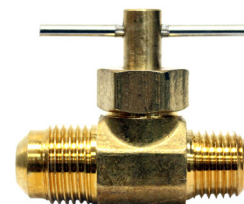



Needle Valves

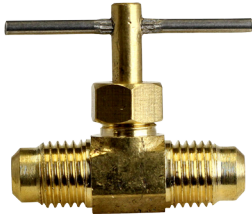

NEEDLE VALVE FLARE TO FLARE

PART NUMBER	O.D. TUBE
P-110SAE	1/4 in x 1/4 in
P-115SAE	3/8 in x 3/8 in

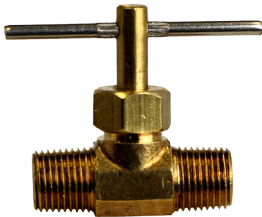

NEEDLE VALVE MPT TO MPT

PART NUMBER	O.D. TUBE
P-108MP	1/4 in x 1/4 in
P-110MP	3/8 in x 3/8 in

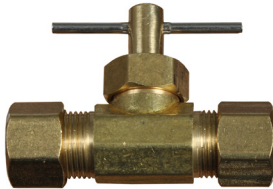

NEEDLE VALVE COMPRESSION TO COMPRESSION

PART NUMBER	O.D. TUBE
P-106CC	1/4 in x 1/4 in
P-107CC	5/16 in x 5/16 in
P-113CC	3/8 in x 3/8 in

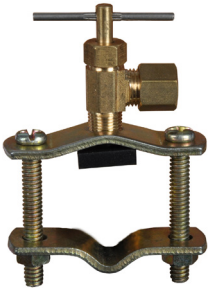

SELF TAPPING VALVE WITH SADDLE

PART NUMBER	O.D. TUBE	PIPE THREAD SIZE
P-104HV-ST	1/4 in	1/8 in

CLAMP FOR USE WITH 3/8" OD THROUGH 1.315" OD TUBE OR PIPE.

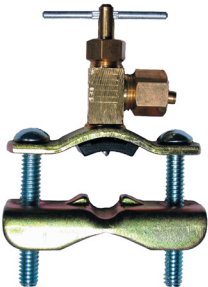

SADDLE VALVE WITH BRASS OR STEEL SADDLE

PART NUMBER	O.D. TUBE	PIPE THREAD SIZE	SADDLE MATERIAL
P-104HV-B	1/4 in	1/8 in	BRASS
P-104HV-S	1/4 in	1/8 in	STEEL

CLAMP FOR USE WITH 3/8" OD THROUGH 1.315" OD TUBE OR PIPE.

Special Duty Valves

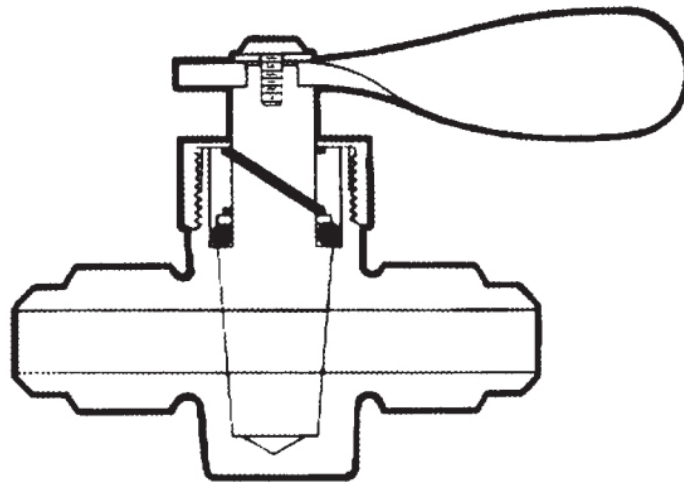

MATERIALS:

- CA377 forged bodies.
- Solid bottom, spring loaded top.
- CAD plated carbon steel handles.
- Packed with non-drying synthetic grease.
- Neoprene O-Ring seal.

WORKING PRESSURE:

30 PSI Maximum based on tube size.
ALWAYS consult tubing specifications.

TEMPERATURE RANGE:

-40 to +250°F
-40 to +121°C

CONFORMANCE:

ALWAYS consult hose and/or tubing specifications for media compatibility, pressure and temperature ratings.

APPLICATIONS:

Used for fuel oil, water, gas, air and LP gas lines that are plumbed with copper, thermoplastic, steel and aluminum tubing.

HOW TO ORDER:

- Order by part number.
- Compression valves are supplied with nuts, and sleeves.
- Some items available on Special Order basis only.

BENEFIT:

- Reduces maintenance costs.
- Safe transfer of recommended fluids.
- Leak free operation

FEATURE:

- Neoprene O-Ring Seal.
- Solid body construction.
- Lapped brass body and plug.

ADVANTAGE:

- Leak free operation.
- Built in durability.
- High quality, low friction valve.



Special Duty Valves

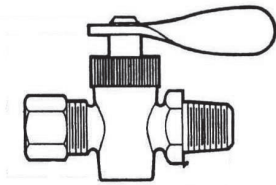

SPECIAL DUTY VALVE COMPRESSION TO MPT

PART NUMBER	O.D. TUBE	PIPE THREAD SIZE
P-57CSD	3/8 in	1/4 in
P-557CSD	3/8 in	3/8 in

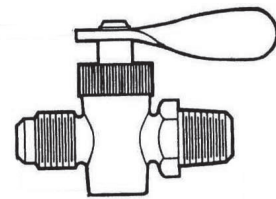

SPECIAL DUTY VALVE FLARE TO MPT

PART NUMBER	O.D. TUBE	PIPE THREAD SIZE
P-227SD	1/4 in	1/4 in
P-57SD	3/8 in	1/4 in
P-557SD	3/8 in	3/8 in
P-67SD	1/2 in	3/8 in

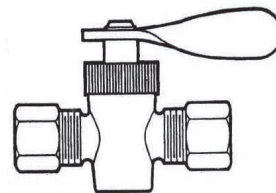

SPECIAL DUTY VALVE COMPRESSION TO COMPRESSION

PART NUMBER	O.D. TUBE
P-58CSD	3/8 in x 3/8 in
P-68CSD	1/2 in x 1/2 in

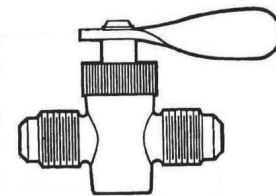

SPECIAL DUTY VALVE FLARE TO FLARE

PART NUMBER	O.D. TUBE
P-28SD	1/4 in x 1/4 in
P-58SD	3/8 in x 3/8 in
P-68SD	1/2 in x 1/2 in



SPECIAL DUTY VALVE FPT TO FPT

PART NUMBER	PIPE THREAD SIZE
P-32SD	1/4 in x 1/4 in
P-40SD	3/8 in x 3/8 in

Special Duty Valves

SPECIAL DUTY VALVE MPT TO MPT

PART NUMBER	PIPE THREAD SIZE
P-77SD	1/4 in x 1/4 in

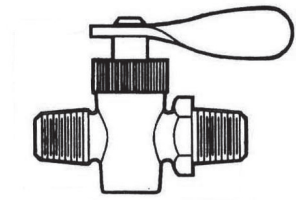

SPECIAL DUTY VALVE FPT TO MPT

PART NUMBER	PIE THREAD SIZE
P-103SD-2	1/8 in x 1/8 in
P-103SD-4	1/4 in x 1/4 in
P-103SD-6	3/8 in x 3/8 in

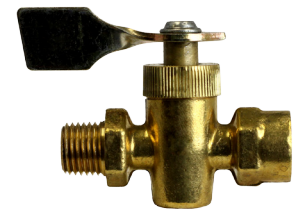

FOUR WAY VALVE FPT ALL ENDS

PART NUMBER	STEM LENGTH	PIPE THREAD SIZE
P-114SD	1-3/8 in	1/4 in



THREE WAY VALVE FPT ALL ENDS

PART NUMBER	PIPE THREAD SIZE
P-108SD-2	1/8 in
P-108SD-4	1/4 in
P-108SD-6	3/8 in





Ground Plug Valves

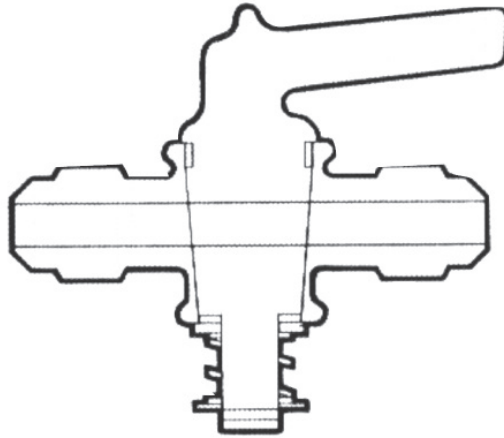

MATERIALS:

CA377 forged bodies.
Handles are integral part of plug.

WORKING PRESSURE:

30 PSI Maximum based on tube size.
ALWAYS consult tubing specifications.

TEMPERATURE RANGE:

-40 to +250°F
-40 to +121°C

CONFORMANCE:

ALWAYS consult hose and/or tubing specifications for media compatibility, pressure and temperature ratings.

APPLICATIONS:

Used for air supply lines and water processing systems plumbed with copper, thermoplastic, and aluminum tubing.

HOW TO ORDER:

- Order by part number.
- Compression valves are supplied with nuts, and sleeves.
- Some items available on Special Order basis only.

BENEFIT:

- Reduces maintenance costs and unsightly leaks.

FEATURE:

- Lapped brass body and plug.

ADVANTAGE:

- Results in high quality, low friction valve.

Ground Plug Valves

VALVE COMPRESSION TO MALE PIPE

PART NUMBER	O.D. TUBE	PIPE THREAD SIZE
P-27CC	1/4 in	1/8 in
P-227CC	1/4 in	1/4 in
P-57CC	3/8 in	1/4 in

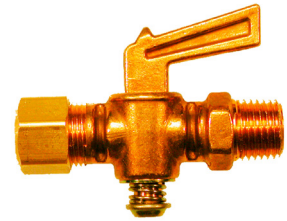

VALVE FLARE TO MPT

PART NUMBER	O.D. TUBE	PIPE THREAD SIZE
P-27SAE	1/4 in	1/8 in
P-227SAE	1/4 in	1/4 in
P-57SAE	3/8 in	1/4 in

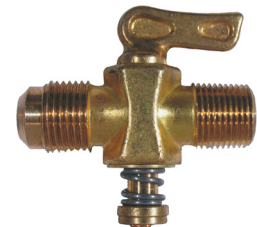

VALVE COMPRESSION TO COMPRESSION

PART NUMBER	O.D. TUBE
P-28CC	1/4 in
P-30CC	5/16 in
P-58CC	3/8 in
P-68CC	1/2 in

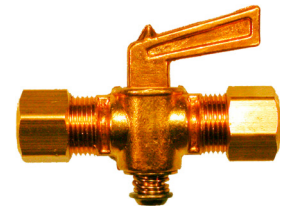

VALVE FLARE TO FLARE

PART NUMBER	O.D. TUBE
P-28SAE	1/4 in
P-58SAE	3/8 in
P-68SAE	1/2 in

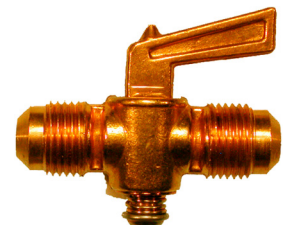

VALVE MPT TO MPT

PART NUMBER	PIPE THREAD SIZE
P-76PC	1/8 in x 1/8 in
P-77PC	1/4 in x 1/4 in
P-78PC	3/8 in x 3/8 in

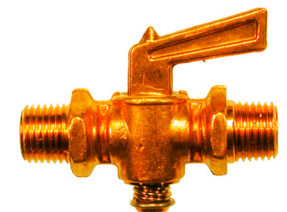



Ground Plug Valves

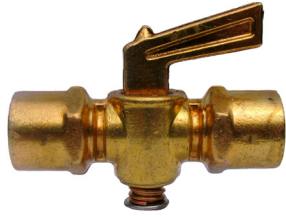

VALVE FPT TO FPT

PART NUMBER	PIPE THREAD SIZE
P-31PC	1/8 in x 1/8 in
P-32PC	1/4 in x 1/4 in
P-40PC	3/8 in x 3/8 in

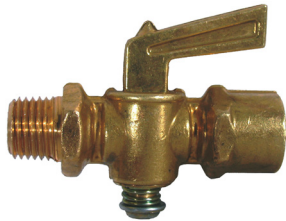

VALVE FPT TO MPT

PART NUMBER	PIPE THREAD SIZE
P-48PC	1/8 in x 1/8 in
P-49PC	1/4 in x 1/4 in
P-50PC	3/8 in x 3/8 in



VALVE FLARE TO FPT

PART NUMBER	O.D. TUBE	PIPE THREAD SIZE
P-161SAE	3/8 in	1/2 in
P-163SAE	3/8 in	3/8 in
P-164SAE	1/2 in	1/2 in

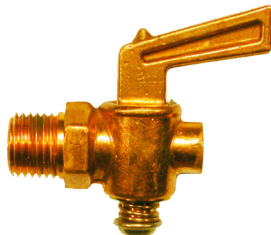

DRAIN VALVE LEVER HANDLE MPT TO DRAIN

PART NUMBER	PIPE THREAD SIZE
P-41D	1/8 in
P-42D	1/4 in
P-43D	3/8 in
P-44D	1/2 in



DRAIN VALVE T HANDLE MPT TO DRAIN

PART NUMBER	PIPE THREAD SIZE
P-37D	1/8 in
P-38D	1/4 in

Hose & Truck Valves

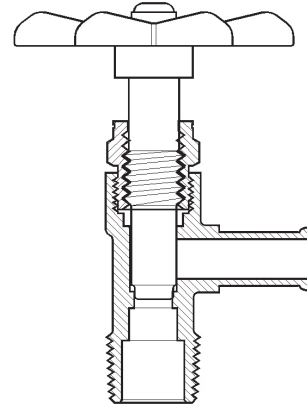
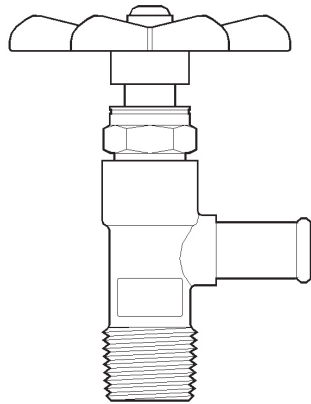

MATERIALS:

CA377 forged bodies.
Handles are integral part of plug.

WORKING PRESSURE:

200 PSI Maximum based on tube size.
ALWAYS consult tubing specifications.

TEMPERATURE RANGE:

-40 to +250°F
-40 to +121°C

CONFORMANCE:

ALWAYS consult hose and/or tubing specifications for media compatibility, pressure and temperature ratings.

APPLICATIONS:

Used in fuel lines, cooling applications, and air systems in the trucking industry. Recommended for gasoline, oil, LP Gas, and kerosene applications.

HOW TO ORDER:

- Order by part number.
- Some items available on Special Order basis only.

BENEFIT:

- Reduced maintenance costs.
- Increased efficiencies

FEATURE:

- Metal to metal internal seat.
- O-Ring sealed.
- Full Flow.

ADVANTAGE:

- Durable Operation.
- Never needs repacking.



Hose & Truck Valves



HOSE VALVE TO MPT

PART NUMBER	I.D. TUBE	PIPE THREAD SIZE
P-HV1-6C	3/8 in	3/8 in
P-HV1-8C	1/2 in	3/8 in
P-HV1-10C	5/8 in	3/8 in
P-HV1-10D	5/8 in	1/2 in
P-HV1-12D	3/4 in	1/2 in

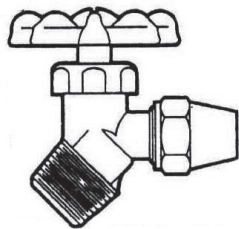

OIL TANK VALVE FLARE TO MPT

PART NUMBER	O.D. TUBE	PIPE THREAD SIZE
P-5818X8	3/8 in	1/2 in
P-5818X12	3/8 in	3/4 in
P-3416X12	1/2 in	3/4 in

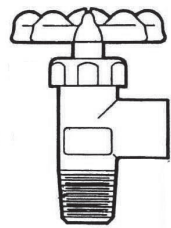

OIL TANK VALVE MPT TO FPT

PART NUMBER	MALE PIPE	FEMALE PIPE
P-1W-86	1/2 in	3/8 in
P-1W-88	1/2 in	1/2 in

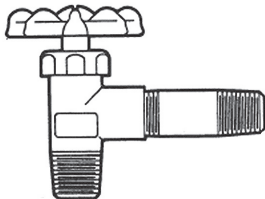

OIL TANK VALVE MPT TO MPT WITH 3-1/2" EXTENSION

PART NUMBER	MALE PIPE	FEMALE PIPE
P-2W-68	3/8 in	3/8 in

Drain Cocks

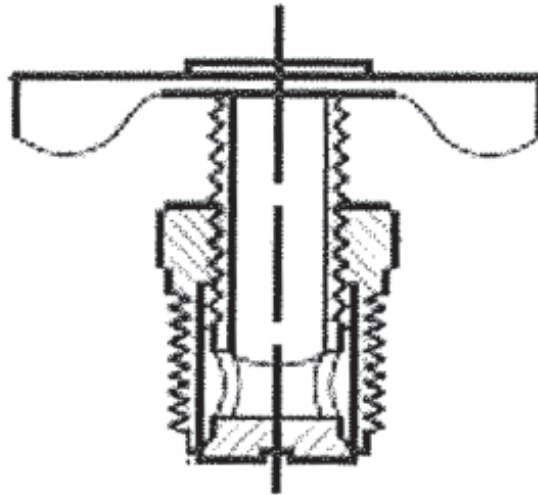

MATERIALS:

CA360

WORKING PRESSURE:

150 PSI Maximum based on tube size.
ALWAYS consult tubing specifications.

TEMPERATURE RANGE:

-65 to +250°F
-54 to +121°C

CONFORMANCE:

ALWAYS consult hose and/or tubing specifications for media compatibility, pressure and temperature ratings.

APPLICATIONS:

Used in low pressure air and water for automotive and industrial applications that are plumbed with copper, thermoplastic, steel and aluminum tubing.

NOT INTENDED FOR LP GAS OR NATURAL GAS.

HOW TO ORDER:

- Order by part number.
- Some items available on Special Order basis only.

BENEFIT:

- Reduces leakage to improve system reliability.
- Eliminate handle breakage.

FEATURE:

- Metal to metal internal seat.
- Pin handle.

ADVANTAGE:

- Positive seal.
- Improved reliability.



Drain Cocks



DRAIN COCK TO MPT

PART NUMBER	PIPE THREAD SIZE
P-200D	1/8 in
P-201D	1/4 in
P-202D	3/8 in



DRAIN COCK HOSE BIBB TO MPT

PART NUMBER	PIPE THREAD SIZE
P-201DH	1/8 in

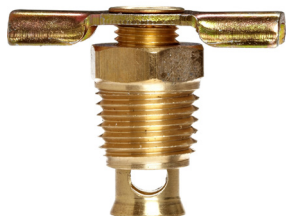

DRAIN COCK INTERNAL SEAT

PART NUMBER	PIPE THREAD SIZE
P-300D	1/8 in

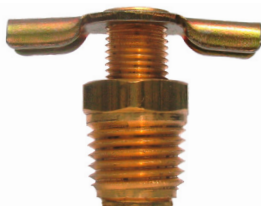

DRAIN COCK EXTERNAL SEAT

PART NUMBER	PIPE THREAD SIZE
P-320D	1/8 in
P-321D	1/4 in
P-322D	3/8 in



DRAIN COCK WITH EXTENSION EXTERNAL SEAT

PART NUMBER	PIPE THREAD SIZE
P-421D	1/4 in

Drain Cocks

AIR COCK

PART NUMBER	DESCRIPTION
P-38	Double female air cock - 1/4"



AIR COCK

PART NUMBER	PIPE THREAD SIZE
P-6	1/8"
P-7	1/4"

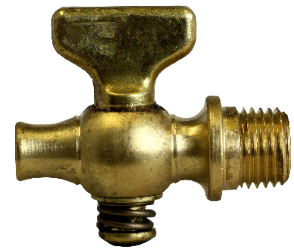

BARREL FAUCET

PART NUMBER	PIPE THREAD SIZE
P-G261	3/4 in





Assortment Kits



Brass Fitting Assortment Kits

Campbell Hausfeld's kit drawer assortments are the ideal way to keep products organized. The sturdy steel construction of the drawer with durable molded plastic compartments withstands the punishment of the most harsh shop environment. Product is easy to locate and inventory is accurately controlled with bar coded layouts.

P-DL20C

18-1/2" L x 12-1/4" W x 3-1/8" D

P-DL16C (Not Pictured)

18-1/4" L x 12" W x 3-1/8" D



Assortment Kits

P-KIT-FASTPIPE-2

1/8" Pipe Kit contains 19 items, and 285 pieces of the most popular tees, elbows, couplings, bushings, plugs and nipples in the product offering.

Designed for P-DL20C drawer.
18-1/2" L x 12-1/4" W x 3-1/8" D

PART NO.	DESCRIPTION	QTY
P-100A-A	1/8" FPT ELBOW	10
P-101A-A	1/8" FPT TEE	10
P-103A-A	1/8" FPT COUPLING	25
P-119A-BA	1/4" X 1/8" COUPLING	10
P-108A-A	1/8" CAP	25
P-109A-A	1/8" SQ HD PLUG	25
P-110A-BA	1/4" X 1/8" HEX BUSHING	25
P-112A-A	1/8" CLOSE NIPPLE	25
P-113A-A15	1/8" X 1-1/2" NIPPLE	10
P-113A-A2	1/8" X 2" NIPPLE	10
P-122A-A	1/8" HEX NIPPLE	25
P-123A-BA	1/4" X 1/8" HEX NIPPLE	10
P-116A-A	1/8" 90° STREET ELBOW	10
P-124A-A	1/8" 45° STREET ELBOW	10
P-127A-A	1/8" STREET TEE	5
P-120A-AA	1/8" FPT X 1/8" MPT CONN	10
P-120A-BA	1/4" FPT X 1/8" MPT CONN	10
P-121A-A	1/8" HEX PLUG	25
P-102A-A	1/8" CROSS	5
P-DL20C	DRAWER	1

P-KIT-FASTPIPE-6

3/8" Pipe Kit contains 19 items, 130 pieces of the most popular tees, elbows, couplings, bushing, plugs and nipples in the product offering.

Designed for P-DL20C drawer.
18-1/2" L x 12-1/4" W x 3-1/8" D

PART NO.	DESCRIPTION	QTY
P-100A-C	3/8" FPT ELBOW	5
P-101A-C	3/8" FPT TEE	5
P-103A-C	3/8" FPT COUPLING	10
P-119A-DC	1/2" X 3/8" COUPLING	5
P-108A-C	3/8" CAP	10
P-109A-C	3/8" SQ HD PLUG	10
P-110A-DC	1/2" X 3/8" HEX BUSHING	10
P-112A-C	3/8" CLOSE NIPPLE	10
P-113A-C15	3/8" X 1-1/2" NIPPLE	5
P-113A-C2	3/8" X 2" NIPPLE	5
P-122A-C	3/8" HEX NIPPLE	10
P-123A-DC	1/2" X 3/8" HEX NIPPLE	5
P-116A-C	3/8" 90° STREET ELBOW	5
P-124A-C	3/8" 45° STREET ELBOW	5
P-127A-C	3/8" STREET TEE	5
P-120A-CC	3/8" FPT X 3/8" MPT CONN	5
P-120A-DC	1/2" FPT X 3/8" MPT CONN	5
P-121A-C	3/8" HEX PLUG	10
P-102A-C	3/8" CROSS	5
P-DL20C	DRAWER	1

P-KIT-FASTPIPE-4

1/4" Pipe Kit contains 19 items, 255 pieces of the most popular tees, elbows, couplings, bushing, plugs and nipples in the product offering.

Designed for P-DL20C drawer.
18-1/2" L x 12-1/4" W x 3-1/8" D

PART NO.	DESCRIPTION	QTY
P-100A-B	1/4" FPT ELBOW	5
P-101A-B	1/4" FPT TEE	5
P-103A-B	1/4" FPT COUPLING	25
P-119A-CB	3/8" X 1/4" COUPLING	5
P-108A-B	1/4" CAP	25
P-109A-B	1/4" SQ HD PLUG	25
P-110A-CB	3/8" X 1/4" HEX BUSHING	25
P-112A-B	1/4" CLOSE NIPPLE	25
P-113A-B15	1/4" X 1-1/2" NIPPLE	5
P-113A-B2	1/4" X 2" NIPPLE	5
P-122A-B	1/4" HEX NIPPLE	25
P-123A-CB	3/8" X 1/4" HEX NIPPLE	5
P-116A-B	1/4" 90° STREET ELBOW	10
P-124A-B	1/4" 45° STREET ELBOW	10
P-127A-B	1/4" STREET TEE	5
P-120A-BB	1/4" FPT X 1/4" MPT CONN	10
P-120A-CB	3/8" FPT X 1/4" MPT CONN	10
P-121A-B	1/4" HEX PLUG	25
P-102A-B	1/4" CROSS	5
P-DL20C	DRAWER	1

P-KIT-FASTPIPE-8

1/2" Pipe Kit contains 18 items, 116 pieces of the most popular tees, elbows, couplings, bushing, plugs and nipples in the product offering.

Designed for P-DL20C drawer.
18-1/2" L x 12-1/4" W x 3-1/8" D

PART NO.	DESCRIPTION	QTY
P-100A-D	1/2" FPT ELBOW	5
P-101A-D	1/2" FPT TEE	5
P-103A-D	1/2" FPT COUPLING	25
P-119A-DB	1/2" X 1/4" COUPLING	5
P-108A-D	1/2" CAP	25
P-109A-D	1/2" SQ HD PLUG	25
P-110A-DB	1/2" X 1/4" HEX BUSHING	25
P-112A-D	1/2" CLOSE NIPPLE	25
P-113A-D15	1/2" X 1-1/2" NIPPLE	5
P-113A-D2	1/2" X 2" NIPPLE	5
P-122A-D	1/2" HEX NIPPLE	25
P-123A-DB	1/2" X 1/4" HEX NIPPLE	5
P-116A-D	1/2" 90° STREET ELBOW	10
P-124A-D	1/2" 45° STREET ELBOW	10
P-120A-DB	1/2" FPT X 1/4" MPT CONN	10
P-120A-DD	1/2" FPT X 1/2" MPT CONN	10
P-121A-D	1/2" HEX PLUG	25
P-102A-D	1/2" CROSS	5
P-DL20C	DRAWER	1



Assortment Kits

P-FA-PIPE-12

3/4" Pipe Kit contains 17 items, 95 pieces of the most popular tees, elbows, couplings, bushing, plugs and nipples in the product offering.

Designed for P-DL20C drawer.
18-1/2" L x 12-1/4" W x 3-1/8" D

PART NO.	DESCRIPTION	QTY
P-100A-E	3/4" FPT ELBOW	4
P-101A-E	3/4" FPT TEE	4
P-103A-E	3/4" FPT COUPLING	5
P-119A-ED	3/4" X 1/2" COUPLING	3
P-108A-E	3/4" CAP	5
P-109A-E	3/4" SQ HD PLUG	10
P-110A-EB	3/4" X 1/4" HEX BUSHING	5
P-110A-EC	3/4" X 3/8" HEX BUSHING	5
P-110A-ED	3/4" X 1/2" HEX BUSHING	10
P-112A-E	3/4" CLOSE NIPPLE	10
P-113A-E15	3/4" X 1-1/2" NIPPLE	5
P-113A-E2	3/4" X 2" NIPPLE	5
P-122A-E	3/4" HEX NIPPLE	5
P-123A-ED	3/4" X 1/2" HEX NIPPLE	3
P-116A-E	3/4" 90° STREET ELBOW	3
P-120A-ED	3/4" FPT X 1/2" MPT CONN	3
P-121A-E	3/4" HEX PLUG	10
P-DL20C	DRAWER	1

P-FA-FL-6

3/8" Flare Kit contains 20 items, 125 pieces of the most popular tees, connector, unions, nuts and elbows in the product offering.

Designed for P-DL20C drawer.
18-1/2" L x 12-1/4" W x 3-1/8" D

PART NO.	DESCRIPTION	QTY
P-N1-6	3/8" SHORT ROD NUT	10
P-N2-6	3/8" LONG ROD NUT	5
P-NS4-6	3/8" SHORT FGD NUT	10
P-N5-6	3/8" FLARE CAP	10
P-P-2-6	3/8" FLARE PLUG	5
P-T2-6	3/8" FLARE TEE	5
P-U2-6	3/8" X 3/8" MALE UNION	5
P-U1-6B	3/8" X 1/4" MALE CONNECTOR	5
P-U1-6C	3/8" X 3/8" MALE CONNECTOR	10
P-U1-6D	3/8" X 1/2" MALE CONNECTOR	10
P-U3-6C	3/8" X 3/8" FEMALE COUPLING	5
P-U3-6D	3/8" X 1/2" FEMALE COUPLING	5
P-E1-6B	3/8" X 1/4" MALE ELBOW	5
P-E1-6C	3/8" X 3/8" MALE ELBOW	5
P-E3-6C	3/8" X 3/8" FEMALE ELBOW	5
P-E3-6D	3/8" X 1/2" FEMALE ELBOW	5
P-E2-6	3/8" X 3/8" FLARE ELBOW	5
P-US4-6	3/8" SWIVEL CONNECTOR	5
P-T1-6B	3/8" X 1/4" MALE TEE	5
P-UR2-64	3/8" X 1/4" RED UNION	5
P-DL20C	DRAWER	1

P-FA-FL-4

1/4" Flare Kit contains 18 items, 155 pieces of the most popular tees, connector, unions, nuts and elbows in the product offering.

Designed for P-DL20C drawer.
18-1/2" L x 12-1/4" W x 3-1/8" D

PART NO.	DESCRIPTION	QTY
P-N1-4	1/4" SHORT ROD NUT	25
P-N2-4	1/4" LONG ROD NUT	5
P-NS4-4	1/4" SHORT FGD NUT	10
P-N5-4	1/4" FLARE CAP	10
P-P-2-4	1/4" FLARE PLUG	5
P-T2-4	1/4" FLARE TEE	5
P-U2-4	1/4" X 1/4" MALE UNION	25
P-U1-4A	1/4" X 1/8" MALE CONNECTOR	10
P-U1-4B	1/4" X 1/4" MALE CONNECTOR	5
P-U3-4A	1/4" X 1/8" FEMALE COUPLING	5
P-U3-4B	1/4" X 1/4" FEMALE COUPLING	5
P-E1-4A	1/4" X 1/8" MALE ELBOW	10
P-E1-4B	1/4" X 1/4" MALE ELBOW	5
P-E3-4A	1/4" X 1/8" FEMALE ELBOW	5
P-E3-4B	1/4" X 1/4" FEMALE ELBOW	5
P-E2-4	1/4" X 1/4" FLARE ELBOW	5
P-US4-4	1/4" SWIVEL CONNECTOR	10
P-T1-4A	1/4" X 1/8" MALE TEE	5
P-DL20C	DRAWER	1

P-FA-FL-8

1/2" Flare Kit contains 19 items, 107 pieces of the most popular tees, connector, unions, nuts and elbows in the product offering.

Designed for P-DL20C drawer.
18-1/2" L x 12-1/4" W x 3-1/8" D

PART NO.	DESCRIPTION	QTY
P-N1-8	1/2" SHORT ROD NUT	10
P-N2-8	1/2" LONG ROD NUT	5
P-NS4-8	1/2" SHORT FGD NUT	10
P-N5-8	1/2" FLARE CAP	10
P-P2-8	1/2" FLARE PLUG	5
P-T2-8	1/2" FLARE TEE	4
P-U2-8	1/2" X 1/2" MALE UNION	5
P-U1-8C	1/2" X 3/8" MALE CONNECTOR	5
P-U1-8D	1/2" X 1/2" MALE CONNECTOR	10
P-U3-8C	1/2" X 3/8" FEMALE COUPLING	5
P-U3-8D	1/2" X 1/2" FEMALE COUPLING	5
P-E1-8C	1/2" X 3/8" MALE ELBOW	3
P-E1-8D	1/2" X 1/2" MALE ELBOW	3
P-E3-8C	1/2" X 3/8" FEMALE ELBOW	5
P-E3-8D	1/2" X 1/2" FEMALE ELBOW	5
P-E2-8	1/2" X 1/2" FLARE ELBOW	5
P-US4-8	1/2" SWIVEL CONNECTOR	5
P-T1-8D	1/2" X 1/2" MALE TEE	2
P-UR2-86	1/2" X 3/8" RED UNION	5
P-DL20C	DRAWER	1



Assortment Kits

P-FA-NAB-20

The Nylon Air Brake Kit contains 20 items, 179 pieces of the most popular DOT nylon airbrake fittings in the product offering.

Designed for P-DL20C drawer.
18-1/2" L x 12-1/4" W x 3-1/8" D

PART NO.	DESCRIPTION	QTY
P-60NAB-4	1/4" NAB SLEEVE	25
P-60NAB-6	3/8" NAB SLEEVE	25
P-60NAB-8	1/2" NAB SLEEVE	10
P-61NAB-4	1/4" NAB NUT	25
P-61NAB-6	3/8" NAB NUT	25
P-61NAB-8	1/2" NAB NUT	10
P-62NAB-4	1/4" X 1/4" NAB UNION	5
P-62NAB-6	3/8" X 3/8" NAB UNION	5
P-62NAB-8	1/2" X 1/2" NAB UNION	3
P-64NAB-4	1/4" X 1/4" X 1/4" NAB TEE	5
P-64NAB-6	3/8" X 3/8" X 3/8" NAB TEE	3
P-64NAB-8	1/2" X 1/2" X 1/2" NAB TEE	3
P-68NAB-4A	1/4" X 1/8" NAB MALE COUPLING	5
P-68NAB-6B	3/8" X 1/4" NAB MALE COUPLING	5
P-68NAB-6C	3/8" X 3/8" NAB MALE COUPLING	5
P-69NAB-4A	1/4" X 1/8" NAB MALE ELBOW	5
P-69NAB-6B	3/8" X 1/4" NAB MALE ELBOW	5
P-69NAB-6C	3/8" X 3/8" NAB MALE ELBOW	5
P-69NAB-8C	1/2" X 3/8" NAB MALE ELBOW	2
P-79NAB-6B	3/8" X 1/4" NAB MALE 45° ELBOW	3
P-DL20C	DRAWER	1

P-FA-COMP-4

1/4" Compression Kit contains 19 items, 283 pieces of the most popular tees, connector, unions, nuts, sleeves and elbows in the product offering.

Designed for P-DL20C drawer.
18-1/2" L x 12-1/4" W x 3-1/8" D

PART NO.	DESCRIPTION	QTY
P-60A-4	1/4" COMP SLEEVE	50
P-61A-4	1/4" COMP NUT	50
P-60AP-4	1/4" DELRIN SLEEVE	25
P-60AE-4	1/4" BRASS INSERT	25
P-62A-44	1/4" X 1/4" COMP UNION	25
P-64A-44	1/4" X 1/4" X 1/4" COMP TEE	5
P-65A-44	1/4" X 1/4" COMP ELBOW	5
P-66A-4A	1/4" X 1/8" FEMALE ADAPTER	10
P-66A-4B	1/4" X 1/4" FEMALE ADAPTER	10
P-66A-4C	1/4" X 3/8" FEMALE ADAPTER	5
P-68A-4A	1/4" X 1/8" MALE CONNECTOR	25
P-68A-4B	1/4" X 1/4" MALE CONNECTOR	10
P-68A-4C	1/4" X 3/8" MALE CONNECTOR	2
P-69A-4A	1/4" X 1/8" MALE ELBOW	10
P-69A-4B	1/4" X 1/4" MALE ELBOW	5
P-70A-4A	1/4" X 1/8" FEMALE ELBOW	5
P-71A-4A	1/4" X 1/8" MALE RUN TEE	2
P-72A-4A	1/4" X 1/8" MALE BRANCH TEE	2
P-72A-4B	1/4" X 1/4" MALE BRANCH TEE	2
P-DL20C	DRAWER	1

P-FA-COMP-6

3/8" Compression Kit contains 19 items, 189 pieces of the most popular tees, connector, unions, nuts, sleeves and elbows in the product offering.

Designed for P-DL20C drawer.
18-1/2" L x 12-1/4" W x 3-1/8" D

PART NO.	DESCRIPTION	QTY
P-60A-6	3/8" COMP SLEEVE	25
P-61A-6	3/8" COMP NUT	25
P-60AP-6	3/8" DELRIN SLEEVE	25
P-60AE-6	3/8" BRASS INSERT	25
P-62A-66	3/8" X 3/8" COMP UNION	10
P-62A-64	3/8" X 1/4" COMP UNION	5
P-64A-66	3/8" X 3/8" X 3/8" COMP TEE	5
P-65A-66	3/8" X 3/8" COMP ELBOW	5
P-66A-6B	3/8" X 1/4" FEMALE ADAPTER	5
P-66A-6C	3/8" X 3/8" FEMALE ADAPTER	5

PART NO.	DESCRIPTION	QTY
P-66A-6D	3/8" X 1/2" FEMALE ADAPTER	5
P-68A-6B	3/8" X 1/4" MALE CONNECTOR	5
P-68A-6C	3/8" X 3/8" MALE CONNECTOR	10
P-68A-6D	3/8" X 1/2" MALE CONNECTOR	10
P-69A-6B	3/8" X 1/4" MALE ELBOW	5
P-69A-6C	3/8" X 3/8" MALE ELBOW	5
P-69A-6D	3/8" X 1/2" MALE ELBOW	5
P-72A-6B	3/8" X 1/4" MALE BRANCH TEE	2
P-72A-6C	3/8" X 3/8" MALE BRANCH TEE	2
P-DL20C	DRAWER	1



Assortment Kits

P-FA-COMP-8

1/2" Compression Kit contains 18 items, 147 pieces of the most popular tees, connector, unions, nuts, sleeves and elbows in the product offering.

Designed for P-DL20C drawer.
18-1/2" L x 12-1/4" W x 3-1/8" D

PART NO.	DESCRIPTION	QTY
P-60A-8	1/2" COMP SLEEVE	25
P-61A-8	1/2" COMP NUT	10
P-60AP-8	1/2" DELRIN SLEEVE	25
P-60AE-8	1/2" BRASS INSERT	25
P-62A-88	1/2" X 1/2" COMP UNION	5
P-62A-86	1/2" X 3/8" COMP UNION	5
P-64A-88	1/2" X 1/2" X 1/2" COMP TEE	4
P-65A-88	1/2" X 1/2" COMP ELBOW	4
P-66A-8C	1/2" X 3/8" FEMALE ADAPTER	5
P-66A-8D	1/2" X 1/2" FEMALE ADAPTER	5
P-68A-8B	1/2" X 1/4" MALE CONNECTOR	5
P-68A-8C	1/2" X 3/8" MALE CONNECTOR	5
P-68A-8D	1/2" X 1/2" MALE CONNECTOR	5
P-69A-8B	1/2" X 1/4" MALE ELBOW	5
P-69A-8C	1/2" X 3/8" MALE ELBOW	5
P-69A-8D	1/2" X 1/2" MALE ELBOW	5
P-72A-8C	1/2" X 3/8" MALE BRANCH TEE	2
P-72A-8D	1/2" X 1/2" MALE BRANCH TEE	2
P-DL20C	DRAWER	1

P-FA-GH-16

The Garden Hose Kit contains 12 items, 100 pieces of the most popular nuts, swivels, connectors and adapters in the product offering.

Designed for P-DL16C drawer.
18-1/4" L x 12" W x 3-1/8" D

PART NO.	DESCRIPTION	QTY
P-19A-12D	3/4" MH X 1/2" MPT HOSE ADPT	10
P-19AF-12DE	3/4" MH X 3/4" MPT W/1/2" TAP	10
P-5AS-12D	3/4" FH X 1/2" FPT SWIVEL	5
P-5AS-12E	3/4" FH X 3/4" FPT SWIVEL	5
P-22AS-12E	3/4" FH X 3/4" FH SWIVEL	10
P-GHN5	3/4" CAP	10
P-18A-12D	3/4" MH X 1/2" FPT HOSE ADPT	10
P-18A-12E	3/4" MH X 3/4" FPT HOSE ADPT	10
P-5A-12D	3/4" FH X 1/2" FPT ADPT	10
P-5A-12E	3/4" FH X 3/4" FPT ADPT	10
P-20A-12D	3/4" FH X 1/2" MPT HOSE ADPT	5
P-20A-12E	3/4" FH X 3/4" MPT HOSE ADPT	5
P-DL16C	DRAWER	1

P-FA-COMP-10

5/8" Compression Kit contains 15 items, 91 pieces of the most popular tees, connector, unions, nuts, sleeves and elbows in the product offering.

Designed for P-DL20C drawer.
18-1/2" L x 12-1/4" W x 3-1/8" D

PART NO.	DESCRIPTION	QTY
P-60A-10	5/8" COMP SLEEVE	10
P-61A-10	5/8" COMP NUT	10
P-60AP-10	5/8" DELRIN SLEEVE	10
P-60AE-10	5/8" BRASS INSERT	10
P-62A-1010	5/8" X 5/8" COMP UNION	10
P-62A-106	5/8" X 3/8" COMP UNION	5
P-62A-108	5/8" X 1/2" COMP UNION	5
P-64A-1010	5/8" X 5/8" X 5/8" COMP TEE	4
P-65A-1010	5/8" X 5/8" COMP ELBOW	4
P-66A-10D	5/8" X 1/2" FEMALE ADAPTER	5
P-68A-10C	5/8" X 3/8" MALE CONNECTOR	5
P-68A-10D	5/8" X 1/2" MALE CONNECTOR	5
P-69A-10D	5/8" X 1/2" MALE ELBOW	4
P-70A-10D	5/8" X 1/2" FEMALE ELBOW	2
P-72A-10D	5/8" X 1/2" MALE BRANCH TEE	2
P-DL20C	DRAWER	1

P-FA-INF-20

The Inverted Flare Kit contains 19 items, 245 pieces of the most popular connector, unions, nuts, and elbows in the product offering.

Designed for P-DL20C drawer.
18-1/2" L x 12-1/4" W x 3-1/8" D

PART NO.	DESCRIPTION	QTY
P-411B-4	1/4" BRASS NUT	25
P-411B-5	5/16" BRASS NUT	25
P-411B-6	3/8" BRASS NUT	25
P-411B-8	1/2" BRASS NUT	10
P-421-4	1/4" UNION	10
P-421-6	3/8" UNION	10
P-481-4A	1/4" X 1/8" MALE CONNECTOR	25
P-481-4B	1/4" X 1/4" MALE CONNECTOR	10
P-481-5A	5/16" X 1/8" MALE CONNECTOR	25
P-481-5B	5/16" X 1/4" MALE CONNECTOR	10
P-481-6A	3/8" X 1/8" MALE CONNECTOR	10
P-481-6B	3/8" X 1/4" MALE CONNECTOR	10
P-481-8C	1/2" X 3/8" MALE CONNECTOR	5
P-481-8D	1/2" X 1/2" MALE CONNECTOR	5
P-491-4A	1/4" X 1/8" MALE ELBOW	10
P-491-4B	1/4" X 1/4" MALE ELBOW	10
P-491-6B	3/8" X 1/4" MALE ELBOW	10
P-491-8C	1/2" X 3/8" MALE ELBOW	5
P-491-8D	1/2" X 1/2" MALE ELBOW	5
P-DL20C	DRAWER	1

Tube Cutter



P-AF20307 - Tube Cutter is designed for Polyethylene, Polypropylene, Nylon and other non-braided thermoplastic tubing for O.D.'s to 1/2 in.



Alpha-Numeric

PART NO.	PAGE	PART NO.	PAGE	PART NO.	PAGE
P-100-45RB	41	P-113RB	44	P-209GHS	62
P-100A	30	P-114SD	79	P-20A	60
P-100A-45	30	P-115SAE	76	P-21A	60
P-100-45RB	31	P-116A	35	P-227CC	81
P-100X	30	P-116X	36	P-227SAE	81
P-100X-45	30	P-116AL	36	P-227SD	78
P-100RB	41	P-116AM	36	P-22A	61
P-101A	30	P-116RB	43	P-22AS	61
P-101X	31	P-117A	36	P-23A	61
P-101CP	75	P-119A	36	P-27CC	81
P-101CP-4	75	P-119AH	37	P-27SAE	81
P-101RB	41	P-119RB	43	P-28CC	81
P-102A	31	P-120A	37	P-28SAE	81
P-102X	31	P-120AH	37	P-28SD	78
P-102CP	75	P-120EC	61	P-2W	84
P-103A	31	P-121A	37	P-300D	86
P-103AH	31	P-121AS	38	P-301	69
P-103CC	75	P-122A	38	P-302	69
P-103-4CC	75	P-122AH	38	P-303	69
P-103RB	41	P-123A	38	P-303ACC	75
P-103SAE	75	P-123AH	39	P-303CC	75
P-103SD	79	P-124A	39	P-303SAE	75
P-104A	32	P-124X	39	P-304	69
P-104HV	76	P-124RB	43	P-305	70
P-104RB	42	P-125RB	43	P-306	70
P-104SAE	75	P-127A	39	P-307	70
P-106CC	76	P-127X	40	P-308	70
P-107CC	76	P-128A	40	P-309	71
P-108A	32	P-129A	40	P-3099	71
P-108MP	76	P-143CP	75	P-30CC	81
P-108RB	42	P-161A	47	P-310	71
P-108SAE	75	P-161SAE	82	P-31NV	75
P-108SD	79	P-163SAE	82	P-31PC	82
P-109A	32	P-164SAE	82	P-320D	86
P-109AS	32	P-18A	60	P-321D	86
P-109CS	32	P-19A	60	P-322D	86
P-109RB	42	P-1W	84	P-32NV	75
P-110A	33	P-200D	86	P-32PC	82
P-110AH	33	P-201A	65	P-32SD	78
P-110FB	33	P-201BF	65	P-37D	82
P-110FRB	42	P-201D	86	P-38	87
P-110MP	73	P-201DH	86	P-38D	82
P-110RB	42	P-201GH	61	P-40PC	82
P-110SAE	76	P-202D	86	P-40SD	78
P-111A	34	P-202GHS	62	P-41D	82
P-112A	34	P-203CC	75	P-411B	27
P-112RB	43	P-209A	66	P-411S	27
P-113A	34	P-209AS	66	P-421D	86
P-113CC	76	P-209ASF	66	P-42D	82

Alpha-Numeric

PART NO.	PAGE	PART NO.	PAGE	PART NO.	PAGE
P-42I	27	P-6	87	P-POL-P2	73
P-43D	82	P-70A	50	P-POL-U2	73
P-44D	82	P-70NAB	58	P-POL-U3	73
P-46I	27	P-71A	50	P-T1	21
P-48I	28	P-VS71NAB	58	P-T2	21
P-48NV	75	P-72A	50	P-T3	21
P-48PC	82	P-VS72NAB	58	P-T9	40
P-49I	28	P-76A	50	P-TR2	22
P-49NV	75	P-76PC	81	P-U1	22
P-49PC	82	P-77PC	81	P-U1CT	24
P-50PC	82	P-77SD	79	P-U1GA	25
P-557CSD	78	P-78PC	81	P-U2	23
P-557SD	78	P-VS79NAB	58	p-U2CT	24
P-57CC	81	P-7	87	P-U3	23
P-57CSD	76	P-81LB	52	P-U3CT	25
P-57SAE	81	P-961A	54	P-U3GA	25
P-57SD	78	P-B1	16	P-UR2	23
P-5818X	84	P-B2	16	P-UR3	24
P-58CC	81	P-C1	16	P-US4	24
P-58CSD	78	P-DE3	16	P-W1	63
P-58SAE	81	P-E1	17		
P-58SD	78	P-E1-45	17		
P-59A	56	P-E2	18		
P-5A	60	P-E3	18		
P-5AS	60	P-E3GA	25		
P-60A	46	P-E4	18		
P-60AE	46	P-ECD-D	62		
P-60AP	46	P-GHN1	63		
P-60NAB	56	P-GHN5	63		
P-61A	46	P-GH-W	62		
P-61NAB	56	P-HBT2	66		
P-62A	47	P-HE1	67		
P-62NAB	56	P-HE1-45	67		
P-64A	47	P-HM	67		
P-64NAB	56	P-HV1	84		
P-65A	48	P-N1	19		
P-65NAB	57	P-N1CT	24		
P-66A	48	P-N2	19		
P-66NAB	57	P-N4	19		
P-67SD	78	P-N5	19		
P-68A	49	P-N5CT	52		
P-68CC	81	P-N5GA	25		
P-68CSD	78	P-NS4	20		
P-VS68NAB	57	P-NSR4	20		
P-68SAE	81	P-P2	20		
P-68SD	78	P-POL-LN	73		
P-6945A	49	P-POL-LTPH	73		
P-69A	50	P-POL-N	73		
P-VS69NAB	57	P-POL-N5	73		



STANDARD TERMS AND CONDITIONS OF SALE

- 1) **ACCEPTANCE; AGREEMENT.** These Terms and Conditions supersede all other terms and conditions, oral or written, and all other communications between the parties suggesting additional or different terms. These Terms and Conditions represent the final and complete understanding of the parties and may be amended or cancelled only by written agreement signed by both parties. These Terms and Conditions expressly limit acceptance to these provisions. No order shall have any force or effect until acknowledged in writing by Seller. Any proposal for additional or different terms or any attempt by Buyer to vary in any degree any of the provisions of these Terms and Conditions is hereby deemed material and is objected to and rejected. No terms of any document or form submitted by Buyer shall be effective to alter or add to the provisions contained in these Terms and Conditions. Unless otherwise stated herein, Buyer's receipt of any portion of the goods ("Goods") shall constitute acceptance of these Terms and Conditions, unless Buyer immediately returns all such Goods.
- 2) **PRICING:** Prices quoted are based on the present cost of metal materials and therefore subject to increases to reflect our material cost on the date raw materials are received. All prices are subject to change without notice. Seller reserves the right to implement price increases/adjustments as deemed necessary.
- 3) **TAXES.** Prices do not include any sales, use, excise, privilege, or other taxes or assessments now or hereafter imposed or levied by or under the authority of any federal, state, or local law, rule, or regulation concerning the Goods sold hereunder or the manufacture or sale thereof. If Seller pays any such taxes or assessments, Buyer shall, upon demand, immediately reimburse Seller for such amounts.
- 4) **TERMS OF PAYMENT.** All payments are due net 30 days from date of invoice. All orders are subject to acceptance at Seller's office. No discounts shall be taken except as specifically allowed in writing by Seller. The price for the Goods and all other amounts due to Seller from Buyer shall be paid without abatement, deduction, or setoff. The date of payment of an invoice shall be the date the payment is received by Seller at the location designated on the invoice.
- 5) **FREIGHT.** Unless otherwise agreed by Seller in writing, all shipments shall be F.O.B. point of manufacture. All risk of loss or damage to Goods shall pass to Buyer upon delivery thereof to Buyer, to its designated agent, or to a carrier for delivery to Buyer, whichever occurs first.
- 6) **DELIVERY.** All shipping and delivery dates are estimates and are based upon prompt receipt of all necessary information from Buyer. Delays in securing Buyer's approval of necessary specifications or samples of products and materials shall, if Seller so chooses, extend the date of delivery. Seller shall not be liable for any claim, loss, expense, or damage of any kind whatsoever for delays in delivery.
- 7) **INSPECTION.** Buyer shall inspect the Goods as soon as possible, but at least within seven days, after receipt, and Buyer shall immediately notify Seller in writing of any claims that the Goods do not conform to Seller's warranty for such Goods.
- 8) **BLANKET ORDERS:** All Goods ordered under a blanket order must be delivered within the agreed-upon time frame, which shall not exceed one year from the date of the blanket order, and shall be delivered in the agreed-upon release quantities.
- 9) **CHANGES: Cancellations and Reschedules:** Changes in specifications or designs relating to any products, changes in delivery schedules or reschedules or cancellations of orders are not permitted unless Seller has accepted same in writing, has determined the additional charge to be made, if any, and the same has been paid by the Buyer.
- 10) **RETURNS.** Goods may not be returned without prior written authorization by Seller. Requests to return Goods must be made within 30 days after receipt of Goods by Buyer. Returns are authorized at Seller's discretion. Goods must be in good condition, in their original packaging and able to be returned to stock. Goods that are made to order, discontinued or custom products are not returnable for credit. All returns must show the return goods authorization number on the boxes. Returns without such information on the boxes will be refused at Seller's dock and returned to Buyer at Buyer's expense. Returns are subject to a 25% restocking fee and must be shipped prepaid.
- 11) **STORAGE.** In absence of agreed shipping dates, Seller shall have the right to invoice Buyer and ship the Goods once they are ready for shipment. If Buyer is unwilling to accept shipment of the Goods on the agreed shipping date or as provided in the prior sentence, Seller may, at its option, place the Goods in storage and bill Buyer for the storage charges. In such case, risk of loss shall pass to Buyer when the Goods are placed in storage, and the date the Goods are placed in storage shall constitute the date of shipment for purposes of beginning the warranty and payment term periods.
- 12) **WARRANTIES AND LIMITATIONS ON WARRANTIES:**
 - a) Seller expressly warrants that, for a period of 12 months after shipment, the Goods (i) will conform to the descriptions and specifications specifically agreed to in writing by Seller and (ii) will be free from defect in material and workmanship. **THESE ARE SELLER'S ONLY WARRANTIES. SELLER MAKES NO OTHER WARRANTY OF ANY KIND WHATSOEVER, EXPRESS OR IMPLIED. ALL IMPLIED WARRANTIES OF MERCHANTABILITY AND/OR FITNESS FOR A PARTICULAR PURPOSE ARE HEREBY DISCLAIMED BY SELLER AND EXCLUDED.**

STANDARD TERMS AND CONDITIONS OF SALE

b) If Buyer notifies Seller in writing within the warranty period of a defect in any Goods sold by Seller to Buyer, and if Seller determines, after appropriate tests and inspection by Seller, that such Goods or part thereof are not in conformity with the warranty given hereunder, Seller will repair or replace, at its sole option, F.O.B. point of manufacture, the defective Goods or part thereof, provided Buyer returns such Goods or part thereof to Seller's plant, freight prepaid. No Goods or part thereof shall be returned without Seller's prior approval. This shall be Buyer's exclusive remedy for Seller's liability hereunder. Any claims not made within the warranty period are deemed waived by Buyer. In lieu of repairing or replacing the defective Goods or part thereof, Seller may, at its sole option, refund the purchase price therefor.

c) Except with respect to title, Seller's warranty does not attach to Goods or parts thereof not manufactured by Seller. Seller will, as an accommodation to Buyer, pass on to Buyer whatever warranty, if any, it receives from the manufacturer of such Goods or part, but only to the extent allowed by such manufacturer.

d) Seller's liability to Buyer or anyone claiming through or on behalf of Buyer, with respect to any claim or loss arising out of any Goods sold by Seller to Buyer or alleged to have resulted from an act or omission of Seller, whether negligent or otherwise, and whether in tort, contract, or otherwise, including failure to deliver, delay in delivery, or breach of warranty, shall be limited to an amount equal to the purchase price of the Goods or part thereof with respect to which such liability is claimed or, where appropriate and at the option of Seller, to replacement of the Goods or part thereof. In no case will Seller be liable for any bodily injury, death, or property damage resulting from or in any way arising out of the Goods or their sale, use, or manufacture. **IN NO EVENT SHALL SELLER BE LIABLE FOR INCIDENTAL OR CONSEQUENTIAL DAMAGES, LOSSES, OR EXPENSES.**

e) If Buyer or any third party repairs or modifies all or part of the Goods without the prior written consent of Seller, or if the Goods are not installed or used in compliance with Seller's directions, this warranty shall be void.

13) INDEMNIFICATION.

a) If the Goods are manufactured in accordance with specifications or other directions provided by Buyer, Buyer shall indemnify, defend, and hold harmless Seller against all claims, losses, liabilities, and expenses (including attorneys' fees), which Seller may incur or become liable to pay with respect to such Goods, including (without limitation) claims relating to patent, trademark, copyright infringement, or unfair competition, claims of non-compliance with any federal, state, or local law or regulation, and any other claim of any third party which relates to or in any way arises out of such specifications or other directions provided by Buyer.

b) Buyer shall indemnify, defend, and hold harmless Seller against all claims, losses, liabilities, and expenses (including attorneys' fees), which Seller may incur or become liable to pay which relate to or in any way arise out of Goods subjected to: (i) improper installation or storage; (ii) accident, damage, abuse or misuse; (iii) abnormal operating conditions or applications; (iv) operating conditions or applications above the rated capacity of the Goods; or (v) a use or application other than or varying in any degree from that for which the goods were designed.

14) **PATENTS.** Except as provided in Section 13 with respect to Goods manufactured in accordance with specifications or directions provided by Buyer, and provided Buyer has made all payments due hereunder, Seller shall defend, at its expense, any suit or proceeding brought against Buyer based upon any claim that the Goods or any part thereof infringe any United States patent issued as of the date of Seller's quotation and shall pay any damages and costs awarded therein against Buyer, provided that Seller is notified promptly in writing of such claim and is given full authority, information and assistance by Buyer to defend or settle the suit. If the Goods or any part thereof are deemed to infringe any such patent, Seller shall, at its expense and sole option either: procure for Buyer the right to continue using said Goods or part; replace them with non-infringing Goods or parts; modify them so they become non-infringing; or remove them and refund the purchase price for them.

15) **SPECIAL TOOLS AND BUYER'S PROPERTY:** Any special tools, jigs, dies, patterns, etc., which Seller makes or acquires for the production of Goods for Buyer shall be and remain Seller's property, notwithstanding any charge Seller may have made therefor. In no event shall Buyer have any interest in any tooling belonging to Seller which is utilized in the production of Goods for Buyer, or which has been converted or adapted by Seller for such use, notwithstanding any charge for any such utilization, conversion or adaptation. Seller shall have the right to alter, discard or otherwise dispose of any items referenced in this paragraph when for three years no orders have been received from the Buyer for products to be made with such items.

16) **SETUP CHARGES:** Setup charges will be applied on special orders the cost of which will be determined on a per order basis.

17) **FORCE MAJEURE.** Seller shall not be liable for any delay in or failure of performance hereunder due to any contingency beyond its reasonable control.

STANDARD TERMS AND CONDITIONS OF SALE

18) **TERMINATION.** Seller shall have the right to terminate this Agreement or to cease work hereunder, in whole or in part, at any time, if (i) Buyer is in default of or commits a breach of any of the provisions of these Terms and Conditions or any other agreement it has with Seller, (ii) a petition initiating a proceeding under any applicable law relating to bankruptcy, insolvency, or reorganization is filed by or against Buyer, (iii) Buyer executes an assignment for benefit or creditors, (iv) a receiver is appointed for Buyer or any substantial part of its assets, or (v) Seller shall have any reasonable ground for insecurity with respect to Buyer's ability to perform and Buyer is unable to provide Seller with adequate assurance of its ability to perform within ten days after written request therefore by Seller.

a) Seller's right to terminate under this section is not an exclusive remedy. Seller shall be entitled to all other rights and remedies it may either at law or in equity. No termination shall affect any accrued rights or obligations of either party as of the effective date of such termination.

19) **WAIVER.** Failure of Seller at any time to require Buyer's performance of any obligation hereunder shall not affect Seller's right to require performance of that obligation. No delay, or omission in the exercise of any right, power, or remedy hereunder shall impair such right, power, or remedy or be considered to be a waiver of any default or acquiescence therein.

20) **MISCELLANEOUS.** Buyer shall not assign any of its rights or obligations hereunder without Seller's prior written consent. These Terms and Conditions shall be construed in accordance with the laws of the State of Illinois without regard to any rules on conflicts of laws. The section headings contained herein are not part of these

Terms and Conditions and are included solely for the convenience of the parties.



100 Production Drive | Harrison, OH 45030 | (800) 241-7335 | Fax: (800) 521-6083 | www.chpower.com

Name of Business: _____

Street Address: _____ Billing Address: _____

City, State, Zip: _____

Telephone No.: _____ Fax No.: _____

Date Established: _____ Corporation _____ Partnership _____ Proprietorship _____

State of Inc. _____

If a subsidiary, name and location of parent _____

If Proprietorship or Partnership, List Owners name, address and phone number _____

Estimated Monthly Purchases \$ _____ Tax Exemption No: _____ (COPY MUST BE ATTACHED)

If Member of Buying Group Name Group _____

_____ Effective Date _____

Financial Statement: _____ (ATTACHED) _____ Available through D&B# _____

Attached to this credit application is the most recent financial statement of the undersigned. The undersigned agrees to provide financial information as a condition of credit and to provide updated financial information as a condition for the continued extension of credit.

CREDIT REFERENCE

Bank Name: _____

Contact: _____ Phone No. _____

Address, City, State & Zip: _____ Account No. _____

TRADE REFERENCES

Name: _____

Contact: _____ Phone No. _____

Address, City, State & Zip: _____

Name: _____

Contact: _____ Phone No. _____

Address, City, State & Zip: _____

Name: _____

Contact: _____ Phone No. _____

Address, City, State & Zip: _____

The undersigned hereby makes this application for credit to Campbell Hausfeld. In making this application, the applicant agrees to pay all amounts within Campbell Hausfeld's terms of sales. If any amounts due are not paid within these terms, the applicant agrees to pay a service charge of 1 1/2% per month (18% per year) or the maximum amount permitted by law, whichever is less. Should it become necessary to place this account with a collection agency or attorney, the applicant agrees to pay all collection costs and attorney fees in addition to all other sums due. The applicant warrants that it has carefully read the above agreement and that it understands and agrees to the same.

Signature: _____ Date: _____ Title: _____



SPECIALIZING IN RESIDENTIAL, COMMERCIAL
AND INDUSTRIAL BRASS FITTINGS.

THE RIGHT FITTING FOR
THE RIGHT JOB. INNOVATION.
PERFORMANCE. DURABILITY.
BUILT ON TRUST.
BUILT ON QUALITY.
SUPERIOR CUSTOMER SERVICE.
IT'S WHAT MAKES US FLOW.

100 PRODUCTION DRIVE - HARRISON, OH 45030 • (800) 241-7335 • CAMPBELLHAUSFELD.COM